



## Installation, Operation and Maintenance Manual

Please read and save these instructions for future reference. Read carefully before attempting to assemble, install, operate or maintain the product described. Protect yourself and others by observing all safety information. Failure to comply with instructions could result in personal injury and/or property damage!

### Model XID Direct Drive

Model XID is a direct drive centrifugal inline exhaust fan. These fans are specifically designed for inline applications. Performance capabilities range up to 5,000 cfm (8,500 m<sup>3</sup>/hr) and up to 2.0 in. wg (498 Pa) of static pressure. XID fans are available in thirteen sizes with nominal wheel diameter ranging from 6 to 16 inches (152 to 406 mm) (060 to 160 unit sizes). Each fan shall bear a permanently affixed manufacturers engraved metal nameplate containing the model number and individual serial number.

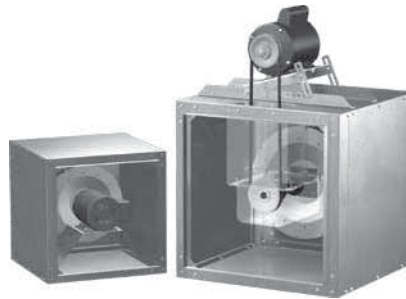

### Model XIB Belt Drive

Model XIB is a belt drive centrifugal inline exhaust fan. These fans are specifically designed for inline applications. Performance capabilities range up to 27,200 cfm (46,200 m<sup>3</sup>/hr) and up to 4.0 in. wg (996 Pa) of static pressure. XIB fans are available in fourteen sizes with nominal wheel diameter ranging from 7 to 42 inches (178 to 1067 mm) (070 to 420 unit sizes). Each fan shall bear a permanently affixed manufacturers engraved metal nameplate containing the model number and individual serial number.

## General Safety Information

Only qualified personnel should install this fan. Personnel should have a clear understanding of these instructions and should be aware of general safety precautions. Improper installation can result in electric shock, possible injury due to coming in contact with moving parts, as well as other potential hazards. Other considerations may be required if seismic activity is present. If more information is needed, contact a licensed professional engineer before moving forward.

1. Follow all local electrical and safety codes, as well as the National Electrical Code (NEC) and the National Fire Protection Agency (NFPA), where applicable. Follow the Canadian Electric Code (CEC) in Canada.
2. The rotation of the wheel is critical. It must be free to rotate without striking or rubbing any stationary objects.
3. Motor must be securely and adequately grounded.
4. Do not spin fan wheel faster than max cataloged fan RPM. Adjustments to fan speed significantly affects motor load. If the fan RPM is changed, the motor current should be checked to make sure it is not exceeding the motor nameplate amps.
5. Do not allow the power cable to kink or come in contact with oil, grease, hot surfaces or chemicals. Replace cord immediately if damaged.
6. Verify that the power source is compatible with the equipment.
7. Never open access doors to a duct while the fan is running.

#### DANGER

Always disconnect, lock and tag power source before installing or servicing. Failure to disconnect power source can result in fire, shock or serious injury.

#### CAUTION

When servicing the fan, motor may be hot enough to cause pain or injury. Allow motor to cool before servicing.

#### CAUTION

Precaution should be taken in explosive atmospheres.

#### DANGER

Pour écarter les risques d'incendie, de choc électrique ou de blessure grave, veiller à toujours débrancher, verrouiller et étiqueter la source de courant avant l'installation ou l'entretien.

#### ATTENTION

Lors de toute intervention sur la soufflante, le moteur peut être suffisamment chaud pour provoquer une douleur voire une blessure. Laisser le moteur refroidir avant toute maintenance.

#### ATTENTION

Faire preuve de précaution dans les atmosphères explosives.

## Receiving

Upon receiving the product check to ensure all items are accounted for by referencing the delivery receipt or packing list. Inspect each crate or carton for shipping damage before accepting delivery. Alert the carrier of any damage detected. The customer will make a notation of damage (or shortage of items) on the delivery receipt and all copies of the bill of lading which is countersigned by the delivering carrier. If damaged, immediately contact Larkin Industries, Inc. Any physical damage to the unit after acceptance is not the responsibility of Larkin Industries, Inc.

## Unpacking

Verify that all required parts and the correct quantity of each item have been received. If any items are missing, report shortages to your local representative to arrange for obtaining missing parts. Sometimes it is not possible that all items for the unit be shipped together due to availability of transportation and truck space. Confirmation of shipment(s) must be limited to only items on the bill of lading.

## Handling

Move fan to desired location and determine position of access panels, discharge and motor. Make sure the inlet and outlet have at least 2½ times the wheel diameter (duct diameter) before any obstructions like an elbow or transition. Attach the fan to a suitable framework as specified; hanging or base vibration isolators are recommended. See the XID & XIB Fan Dimensions table on page 4 and 5 for physical dimensions, utilizing Figures 1 and 2. Mounting dimensions and vibration isolator centerline information is provided on pages 6 thru 9. The motor's amperage and voltage ratings must be checked for compatibility to supply voltage prior to final electrical connection. Electrical lead-in wires are then connected to the factory supplied safety disconnect switch. All wiring must conform to local and national codes.

## Fan Storage

Fans are protected against damage during shipment. If the unit cannot be installed and operated immediately, precautions need to be taken to prevent deterioration of the unit during storage. The user assumes responsibility of the fan and accessories while in storage. The manufacturer will not be responsible for damage during storage. These suggestions are provided solely as a convenience to the user.

## Indoor Storage

The ideal environment for the storage of fans and accessories is indoors, above grade, in a low humidity atmosphere which is sealed to prevent the entry of blowing dust, rain or snow. Temperatures should be evenly maintained between 30° to 110°F (-1° to 43°C) (wide temperature swings may cause condensation and “sweating” of metal parts). All accessories must be stored indoors in a clean, dry atmosphere.

Remove any accumulations of dirt, water, ice or snow

and wipe dry before moving to indoor storage. To avoid “sweating” of metal parts allow cold parts to reach room temperature. To dry parts and packages use a portable electric heater to get rid of any moisture buildup. Leave coverings loose to permit air circulation and to allow for periodic inspection.

The unit should be stored at least 3½ in. (89 mm) off the floor on wooden blocks covered with moisture proof paper or polyethylene sheathing. Aisles between parts and along all walls should be provided to permit air circulation and space for inspection.

## Outdoor Storage

Fans designed for outdoor applications may be stored outdoors, if absolutely necessary. Roads or aisles for portable cranes and hauling equipment are needed.

The fan should be placed on a level surface to prevent water from leaking into the fan. The fan should be elevated on an adequate number of wooden blocks so that it is above water and snow levels and has enough blocking to prevent it from settling into soft ground. Locate parts far enough apart to permit air circulation, sunlight and space for periodic inspection. To minimize water accumulation, place all fan parts on blocking supports so that rain water will run off.

Do not cover parts with plastic film or tarps as these cause condensation of moisture from the air passing through heating and cooling cycles.

Fan wheels should be blocked to prevent spinning caused by strong winds.

## Inspection and Maintenance During Storage

While in storage, inspect fans once per month. Keep a record of inspection and maintenance performed.

If moisture or dirt accumulations are found on parts, the source should be located and eliminated. At each inspection, rotate the wheel by hand ten to fifteen revolutions to distribute lubricant on motor. If paint deterioration begins, consideration should be given to touch-up or repainting. Fans with special coatings may require special techniques for touch-up or repair.

Machined parts coated with rust preventive should be restored to good condition promptly if signs of rust occur. Immediately remove the original rust preventive coating with petroleum solvent and clean with lint-free cloths. Polish any remaining rust from surface with crocus cloth or fine emery paper and oil. Do not destroy the continuity of the surfaces. Thoroughly wipe clean with Tectyl® 506 (Ashland Inc.) or the equivalent. For hard to reach internal surfaces or for occasional use, consider using Tectyl® 511M Rust Preventive, WD-40® or the equivalent.

## Removing From Storage

As fans are removed from storage to be installed in their final location, they should be protected and maintained in a similar fashion until the fan equipment goes into operation.

# Redesigned XIB Dimensions

---

In early 2015, the XIB was redesigned. The redesign changes some mounting dimensions of the fan for sizes 70 through 240. All XIB fans ordered after July 20th, 2015 will be moving over to this new design, with two exceptions that will still utilize the old design:

1. Any orders prior to July 20th, 2015.
2. Any orders for OSHPD seismic rated units.

Both versions of the fan have their dimensions listed, so it is recommended that the dimensions should be confirmed on these models before the unit is installed. Contact your local sales representative for clarification on ordering information.

## XID & XIB Fan Dimensions

Model	A	B	C	*D	E	*F	*G	*H	Damper	XID Weight <sup>^</sup>	XIB Weight <sup>^</sup>
XID 60-75	12 (305)	13 (330)	12 (305)	8 <sup>7</sup> / <sub>8</sub> (225)	1 (25)	-	-	-	9 (229)	26 (12)	-
XID 80-95	15 (381)	16 (406)	15 (381)	11 <sup>1</sup> / <sub>8</sub> (302)	1 (25)	-	-	-	12 (305)	41 (19)	-
XIB 70-80	15 (381)	21 (533)	15 (381)	11 <sup>1</sup> / <sub>8</sub> (302)	1 (25)	15 <sup>1</sup> / <sub>2</sub> (394)	14 (356)	12 <sup>1</sup> / <sub>2</sub> (318)	12 (305)	-	76 (34)
XIB 90	15 (381)	21 (533)	15 (381)	11 <sup>1</sup> / <sub>8</sub> (302)	1 (25)	15 <sup>1</sup> / <sub>2</sub> (394)	14 (356)	12 <sup>1</sup> / <sub>2</sub> (318)	12 (305)	-	84 (38)
XID-XIB 100	17 (432)	21 (533)	17 (432)	13 <sup>3</sup> / <sub>8</sub> (352)	1 (25)	15 <sup>1</sup> / <sub>2</sub> (394)	14 (356)	12 <sup>1</sup> / <sub>2</sub> (318)	14 (356)	56 (25)	83 (38)
XID-XIB 120	19 (483)	21 (533)	19 (483)	15 <sup>1</sup> / <sub>8</sub> (403)	1 (25)	17 <sup>1</sup> / <sub>8</sub> (454)	16 (406)	12 <sup>1</sup> / <sub>2</sub> (318)	16 (406)	67 (30)	97 (44)
XID-XIB 130 (HP)	21 (533)	21 (533)	21 (533)	17 <sup>1</sup> / <sub>8</sub> (454)	1 (25)	17 <sup>1</sup> / <sub>8</sub> (454)	16 (406)	12 <sup>1</sup> / <sub>2</sub> (318)	18 (457)	67 (35)	97 (44)
XID-XIB 140 (HP)	23 (584)	22 (559)	23 (584)	19 <sup>1</sup> / <sub>8</sub> (505)	1 (25)	17 <sup>1</sup> / <sub>8</sub> (454)	16 (406)	12 <sup>1</sup> / <sub>2</sub> (318)	20 (508)	104 (47)	111 (50)
XID-XIB 160 (HP)	26 (660)	26 (660)	26 (660)	22 <sup>1</sup> / <sub>8</sub> (581)	1 (25)	20 <sup>1</sup> / <sub>2</sub> (521)	17 (432)	13 <sup>3</sup> / <sub>8</sub> (340)	23 (584)	160 (73)	208 (94)
XIB 180 (HP)	28 (711)	28 (711)	28 (711)	23 <sup>3</sup> / <sub>8</sub> (606)	1 <sup>1</sup> / <sub>2</sub> (38)	24 <sup>3</sup> / <sub>8</sub> (619)	18 (457)	13 <sup>3</sup> / <sub>8</sub> (349)	24 (610)	26 (12)	245 (111)
XIB 200 (HP)	32 (813)	32 (813)	32 (813)	27 <sup>1</sup> / <sub>8</sub> (708)	1 <sup>1</sup> / <sub>2</sub> (38)	28 (711)	20 (508)	16 (406)	28 (711)	26 (12)	314 (142)
XIB 240 (HP)	39 (991)	34 (864)	39 (991)	34 <sup>3</sup> / <sub>8</sub> (886)	1 <sup>1</sup> / <sub>2</sub> (38)	32 <sup>1</sup> / <sub>8</sub> (835)	22 (559)	19 (483)	35 (889)	26 (12)	415 (188)
XIB 300 (HP)	46 (1168)	38 (965)	46 (1168)	41 <sup>1</sup> / <sub>8</sub> (1064)	1 <sup>1</sup> / <sub>2</sub> (38)	34 (864)	22 (559)	18 (457)	42 (1067)	26 (12)	537 (244)
XIB 360 (HP)	52 (1321)	42 (1067)	52 (1321)	47 <sup>1</sup> / <sub>8</sub> (1216)	1 <sup>1</sup> / <sub>2</sub> (38)	34 (864)	22 (559)	18 (457)	48 (1219)	26 (12)	686 (311)
XIB 420 (HP)	58 (1473)	50 (1270)	58 (1473)	53 <sup>3</sup> / <sub>8</sub> (1368)	1 <sup>1</sup> / <sub>2</sub> (38)	34 (864)	22 (559)	18 (457)	54 (1372)	26 (12)	789 (358)

All dimensions in inches (millimeters) and weight is shown in pounds (kilograms). \*May be greater depending on motor.

<sup>^</sup>Weight shown is largest cataloged Open Drip Proof motor.

## Filter Option Dimensions

Model	A	B	C	D	WT.	Filter Size	Filter Quantity
XID 60-75	22 <sup>1</sup> / <sub>8</sub> (562)	12 (305)	8 <sup>7</sup> / <sub>8</sub> (225)	1 (25)	40 (18)	10 x 12 (254 x 305)	1
XID 80-95	45 <sup>5</sup> / <sub>8</sub> (1159)	15 (381)	11 <sup>1</sup> / <sub>8</sub> (302)	1 (25)	74 (34)	14 x 25 (356 x 635)	1
XID 100	47 <sup>1</sup> / <sub>4</sub> (1200)	17 (432)	13 <sup>1</sup> / <sub>8</sub> (352)	1 (25)	88 (40)	16 x 20 (406 x 508)	2
XID 120	52 <sup>3</sup> / <sub>16</sub> (1326)	19 (483)	15 <sup>1</sup> / <sub>8</sub> (403)	1 (25)	114 (52)	16 x 25 (406 x 635)	2
XID 130	46 <sup>3</sup> / <sub>8</sub> (1178)	21 (533)	17 <sup>1</sup> / <sub>8</sub> (454)	1 (25)	120 (54)	20 x 20 (508 x 508)	2
XID 140	52 <sup>3</sup> / <sub>8</sub> (1330)	23 (584)	19 <sup>1</sup> / <sub>8</sub> (505)	1 (25)	174 (79)	20 x 25 (508 x 635)	2
XID 160	51 <sup>1</sup> / <sub>8</sub> (1305)	26 (660)	22 <sup>1</sup> / <sub>8</sub> (581)	1 (25)	246 (112)	20 x 20 (508 x 508)	4
XIB 70-80-90	50 <sup>5</sup> / <sub>8</sub> (1286)	15 (381)	11 <sup>1</sup> / <sub>8</sub> (302)	1 (25)	117 (53)	14 x 25 (356 x 635)	1
XIB 100	47 <sup>1</sup> / <sub>4</sub> (1200)	17 (432)	13 <sup>1</sup> / <sub>8</sub> (352)	1 (25)	120 (54)	16 x 20 (406 x 508)	2
XIB 120	52 <sup>3</sup> / <sub>16</sub> (1326)	19 (483)	15 <sup>1</sup> / <sub>8</sub> (403)	1 (25)	144 (79)	16 x 25 (406 x 635)	2
XIB 130 (HP)	46 <sup>3</sup> / <sub>8</sub> (1178)	21 (533)	17 <sup>1</sup> / <sub>8</sub> (454)	1 (25)	140 (64)	20 x 20 (508 x 508)	2
XIB 140 (HP)	52 <sup>3</sup> / <sub>8</sub> (1330)	23 (584)	19 <sup>1</sup> / <sub>8</sub> (505)	1 (25)	181 (82)	20 x 25 (508 x 635)	2
XIB 160 (HP)	51 <sup>1</sup> / <sub>8</sub> (1305)	26 (660)	22 <sup>1</sup> / <sub>8</sub> (581)	1 (25)	294 (133)	20 x 20 (508 x 508)	4
XIB 180 (HP)	55 <sup>1</sup> / <sub>16</sub> (1399)	28 (711)	23 <sup>3</sup> / <sub>8</sub> (606)	1 <sup>1</sup> / <sub>2</sub> (38)	344 (156)	20 x 25 (508 x 635)	4
XIB 200 (HP)	66 <sup>1</sup> / <sub>16</sub> (1694)	32 (813)	27 <sup>1</sup> / <sub>8</sub> (708)	1 <sup>1</sup> / <sub>2</sub> (38)	441 (200)	12 x 25 (305 x 635)	3
						16 x 25 (406 x 635)	3
XIB 240 (HP)	68 <sup>7</sup> / <sub>8</sub> (1749)	39 (991)	34 <sup>3</sup> / <sub>8</sub> (886)	1 <sup>1</sup> / <sub>2</sub> (38)	573 (260)	20 x 25 (508 x 635)	4
						16 x 25 (406 x 635)	4
XIB 300 (HP)	72 <sup>1</sup> / <sub>8</sub> (1832)	46 (1168)	41 <sup>1</sup> / <sub>8</sub> (1064)	1 <sup>1</sup> / <sub>2</sub> (38)	759 (344)	20 x 25 (508 x 635)	8
XIB 360 (HP)	79 <sup>1</sup> / <sub>4</sub> (2013)	52 (1321)	47 <sup>1</sup> / <sub>8</sub> (1216)	1 <sup>1</sup> / <sub>2</sub> (38)	957 (434)	16 x 25 (406 x 635)	10
						20 x 25 (508 x 635)	5
XIB 420	93 <sup>3</sup> / <sub>8</sub> (2365)	58 (1473)	53 <sup>3</sup> / <sub>8</sub> (1368)	1 <sup>1</sup> / <sub>2</sub> (38)	1185 (538)	16 x 25 (406 x 635)	5
						20 x 25 (508 x 635)	10

Note: 24-inch side clearance is recommended for accessing and removing filters. All dimensions in inches (millimeters) and weight (WT.) in pounds (kilograms).

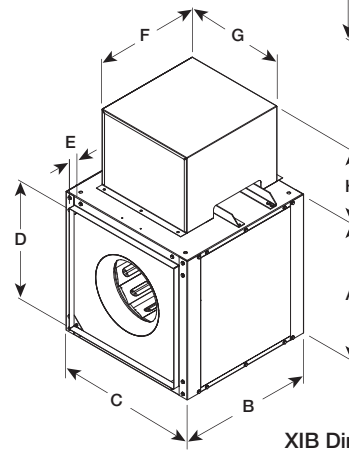
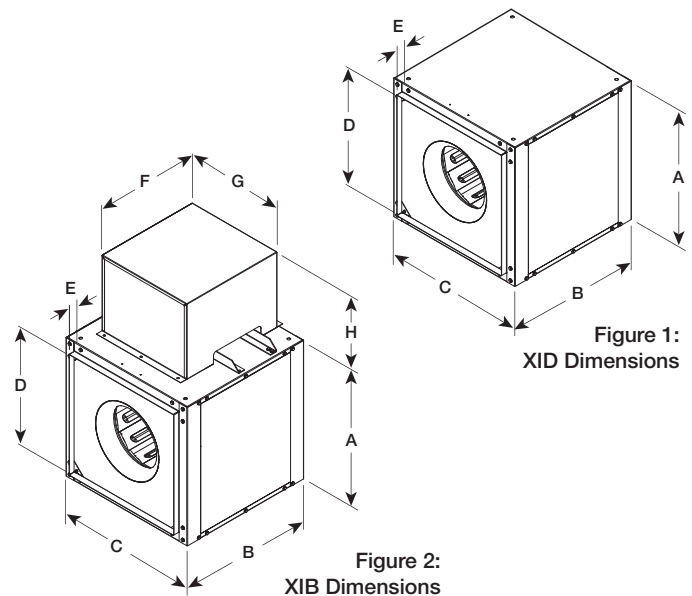

Figure 3: Model XID - Filter Options

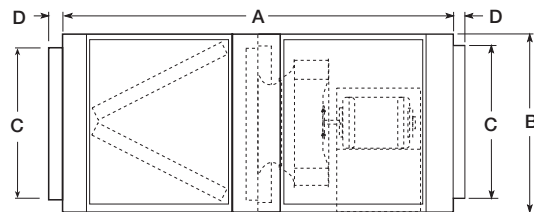
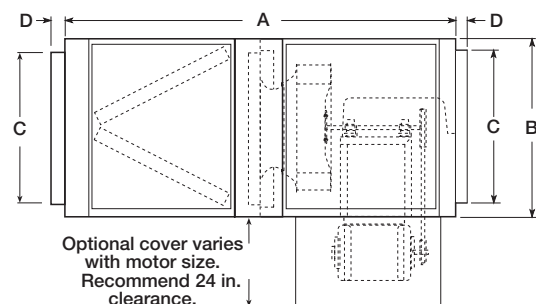

Figure 4: Model XIB - Filter Options



# Redesigned XIB Dimensions (refer to page 3 for details)

XIB Fan Dimensions										
Model	A	B	C	*D	E	*F	*G	*H	Damper	XIB Weight <sup>^</sup>
XIB 70-90	17 <sup>1</sup> / <sub>8</sub> (435)	21 (533)	17 <sup>1</sup> / <sub>8</sub> (435)	11 <sup>1</sup> / <sub>8</sub> (302)	1 <sup>1</sup> / <sub>2</sub> (37)	17 <sup>3</sup> / <sub>4</sub> (451)	13 (330)	13 <sup>1</sup> / <sub>4</sub> (337)	12 (305)	106 (48)
XIB 100	17 <sup>1</sup> / <sub>8</sub> (435)	21 (533)	17 <sup>1</sup> / <sub>8</sub> (435)	13 <sup>3</sup> / <sub>8</sub> (352)	1 <sup>1</sup> / <sub>2</sub> (37)	17 <sup>3</sup> / <sub>4</sub> (451)	13 (330)	13 <sup>1</sup> / <sub>4</sub> (337)	14 (356)	107 (48)
XIB 120	19 <sup>1</sup> / <sub>8</sub> (486)	21 (533)	19 <sup>1</sup> / <sub>8</sub> (486)	15 <sup>5</sup> / <sub>8</sub> (403)	1 <sup>1</sup> / <sub>2</sub> (37)	20 (508)	17 (432)	13 <sup>1</sup> / <sub>4</sub> (337)	16 (406)	124(56)
XIB 130 (HP)	21 <sup>1</sup> / <sub>8</sub> (537)	21 (533)	21 <sup>1</sup> / <sub>8</sub> (537)	17 <sup>7</sup> / <sub>8</sub> (454)	1 <sup>1</sup> / <sub>2</sub> (37)	20 (508)	17 (432)	13 <sup>1</sup> / <sub>4</sub> (337)	18 (457)	131 (59)
XIB 140 (HP)	23 <sup>1</sup> / <sub>8</sub> (587)	22 (559)	23 <sup>1</sup> / <sub>8</sub> (587)	19 <sup>7</sup> / <sub>8</sub> (505)	1 <sup>1</sup> / <sub>2</sub> (37)	20 (508)	17 (432)	13 <sup>1</sup> / <sub>4</sub> (337)	20 (508)	146 (66)
XIB 160 (HP)	26 <sup>1</sup> / <sub>8</sub> (664)	26 (660)	26 <sup>1</sup> / <sub>8</sub> (664)	22 <sup>7</sup> / <sub>8</sub> (581)	1 <sup>1</sup> / <sub>2</sub> (37)	20 (508)	17 (432)	13 <sup>1</sup> / <sub>4</sub> (337)	23 (584)	188 (85)
XIB 180 (HP)	27 <sup>1</sup> / <sub>8</sub> (689)	28 (711)	27 <sup>1</sup> / <sub>8</sub> (689)	23 <sup>3</sup> / <sub>8</sub> (606)	1 <sup>1</sup> / <sub>2</sub> (37)	20 (508)	17 (432)	13 <sup>1</sup> / <sub>4</sub> (337)	24 (610)	195 (88)
XIB 200 (HP)	31 <sup>1</sup> / <sub>8</sub> (791)	32 (813)	31 <sup>1</sup> / <sub>8</sub> (791)	27 <sup>3</sup> / <sub>8</sub> (708)	1 <sup>1</sup> / <sub>2</sub> (37)	30 (762)	20 (508)	16 (406)	28 (711)	246 (111)
XIB 240 (HP)	38 <sup>1</sup> / <sub>8</sub> (968)	34 (864)	38 <sup>1</sup> / <sub>8</sub> (968)	34 <sup>7</sup> / <sub>8</sub> (886)	1 <sup>1</sup> / <sub>2</sub> (37)	30 (762)	20 (508)	16 (406)	35 (889)	350 (159)

All dimensions in inches (millimeters) and weight is shown in pounds (kilograms). \*May be greater depending on motor.  
<sup>^</sup>Weight shown is largest cataloged Open Drip Proof motor.

Filter Option Dimensions							
Model	A	B	C	D	WT.	Filter Size	Filter Quantity
XIB 70-80-90	53 <sup>7</sup> / <sub>8</sub> (1368)	17 <sup>1</sup> / <sub>8</sub> (435)	11 <sup>1</sup> / <sub>8</sub> (302)	1 <sup>1</sup> / <sub>2</sub> (37)	168 (76)	16 x 20 (406 x 508)	2
XIB 100	53 <sup>7</sup> / <sub>8</sub> (1368)	17 <sup>1</sup> / <sub>8</sub> (435)	13 <sup>3</sup> / <sub>8</sub> (352)	1 <sup>1</sup> / <sub>2</sub> (37)	169 (77)	16 x 20 (406 x 508)	2
XIB 120	58 <sup>3</sup> / <sub>4</sub> (1492)	19 <sup>1</sup> / <sub>8</sub> (486)	15 <sup>5</sup> / <sub>8</sub> (403)	1 <sup>1</sup> / <sub>2</sub> (37)	194 (88)	16 x 25 (406 x 635)	2
XIB 130 (HP)	53 <sup>3</sup> / <sub>4</sub> (1353)	21 <sup>1</sup> / <sub>8</sub> (537)	17 <sup>1</sup> / <sub>8</sub> (454)	1 <sup>1</sup> / <sub>2</sub> (37)	197 (89)	20 x 20 (508 x 508)	2
XIB 140 (HP)	59 (1500)	23 <sup>1</sup> / <sub>8</sub> (537)	19 <sup>1</sup> / <sub>8</sub> (505)	1 <sup>1</sup> / <sub>2</sub> (37)	231 (105)	20 x 25 (508 x 635)	2
XIB 160 (HP)	58 <sup>3</sup> / <sub>4</sub> (1492)	26 <sup>1</sup> / <sub>8</sub> (664)	22 <sup>7</sup> / <sub>8</sub> (581)	1 <sup>1</sup> / <sub>2</sub> (37)	285 (129)	20 x 20 (508 x 508)	4
XIB 180 (HP)	60 <sup>3</sup> / <sub>4</sub> (1543)	27 <sup>1</sup> / <sub>8</sub> (689)	23 <sup>3</sup> / <sub>8</sub> (606)	1 <sup>1</sup> / <sub>2</sub> (37)	293 (133)	20 x 25 (508 x 635)	4
XIB 200 (HP)	69 <sup>3</sup> / <sub>8</sub> (1762)	31 <sup>1</sup> / <sub>8</sub> (791)	27 <sup>3</sup> / <sub>8</sub> (708)	1 <sup>1</sup> / <sub>2</sub> (37)	361 (164)	12 x 25 (305 x 635)	3
						16 x 25 (406 x 635)	3
XIB 240 (HP)	71 <sup>1</sup> / <sub>2</sub> (1816)	38 <sup>1</sup> / <sub>8</sub> (968)	34 <sup>7</sup> / <sub>8</sub> (886)	1 <sup>1</sup> / <sub>2</sub> (37)	496 (225)	20 x 25 (508 x 635)	4
						16 x 25 (406 x 635)	4

Note: 24-inch side clearance is recommended for accessing and removing filters. All dimensions in inches (millimeters) and weight (WT.) in pounds (kilograms).

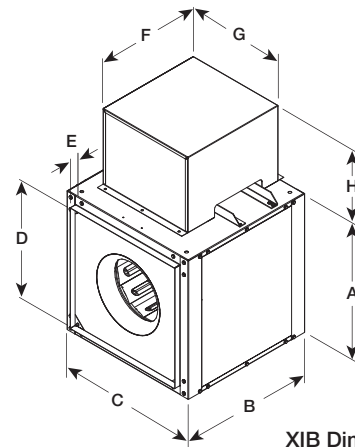
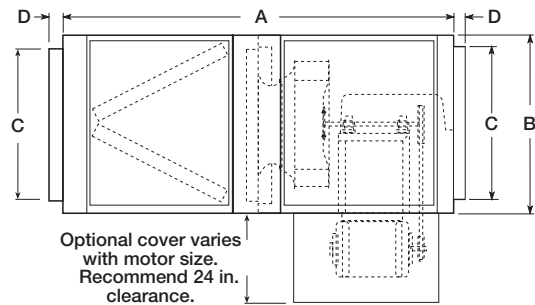

Figure 2: XIB Dimensions

Figure 4: Model XIB - Filter Options



## Mounting: XID /XIB

All XID and XIB fan models can be mounted horizontally, vertically or at an angle. For ease of installation, knockouts are provided at each location where mounting brackets are shown in Figures 5, 6 and 7. Optional brackets are universally adjustable to mount in any of these locations.

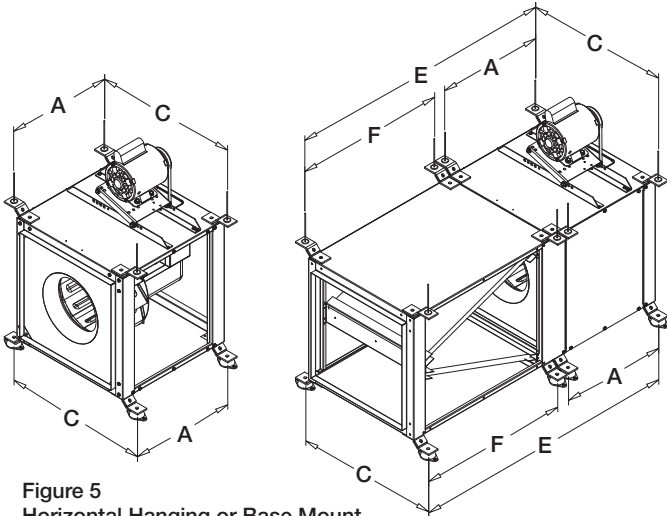

Figure 5  
Horizontal Hanging or Base Mount

With either a hanging or base mount the motor may be located on either side. The base mount allows top access panels only.

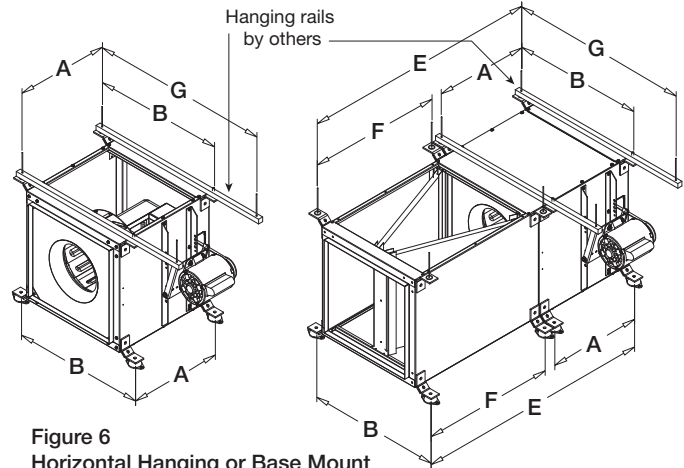

Figure 6  
Horizontal Hanging or Base Mount

With a hanging mount, the motor may be located on either top or bottom. The base mount allows top motor location only. Both options provide access panels on two sides.

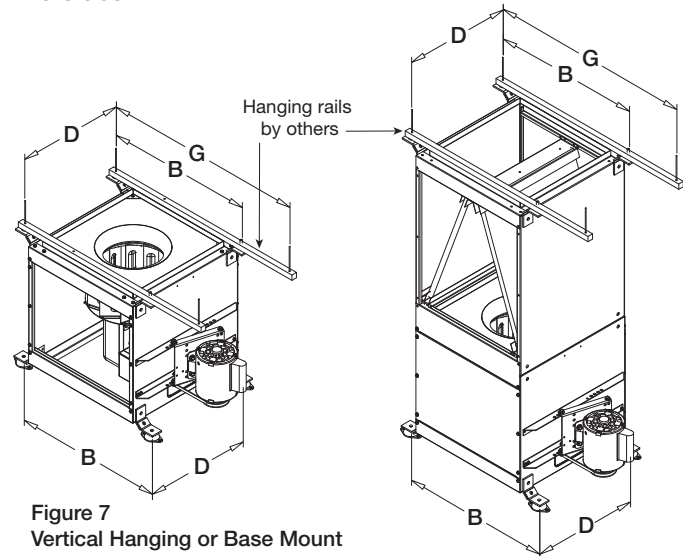

Figure 7  
Vertical Hanging or Base Mount

Mounting brackets are turned 90° for vertical mounting. Access panels are located on the two sides adjacent to the motor.

Mounting Dimensional Data							
Model	A	B	C	D	E	F	G
XID 60-75	10 <sup>5</sup> / <sub>8</sub> (270)	17 (432)	15 <sup>3</sup> / <sub>4</sub> (400)	8 <sup>7</sup> / <sub>8</sub> (225)	19 <sup>3</sup> / <sub>4</sub> (502)	7 (178)	Hanging rails not included. Supplied by others.
XID 80-95	13 <sup>1</sup> / <sub>4</sub> (337)	20 (508)	18 <sup>3</sup> / <sub>4</sub> (476)	11 <sup>7</sup> / <sub>8</sub> (302)	43 (1092)	27 <sup>3</sup> / <sub>8</sub> (695)	
XIB 70-90	18 <sup>5</sup> / <sub>8</sub> (473)	20 <sup>7</sup> / <sub>8</sub> (511)	18 <sup>3</sup> / <sub>4</sub> (476)	11 <sup>7</sup> / <sub>8</sub> (302)	48 <sup>5</sup> / <sub>16</sub> (1227)	27 <sup>3</sup> / <sub>8</sub> (695)	
XID-XIB 100	18 <sup>5</sup> / <sub>8</sub> (473)	22 <sup>7</sup> / <sub>8</sub> (562)	20 <sup>3</sup> / <sub>4</sub> (527)	13 <sup>7</sup> / <sub>8</sub> (352)	44 <sup>7</sup> / <sub>8</sub> (1140)	24 (610)	
XID-XIB 120	18 <sup>5</sup> / <sub>8</sub> (473)	24 (610)	22 <sup>3</sup> / <sub>4</sub> (578)	16 (406)	49 <sup>9</sup> / <sub>8</sub> (1254)	28 <sup>7</sup> / <sub>8</sub> (714)	
XID-XIB 130	18 <sup>5</sup> / <sub>8</sub> (473)	26 <sup>7</sup> / <sub>8</sub> (664)	24 <sup>3</sup> / <sub>4</sub> (629)	17 <sup>7</sup> / <sub>8</sub> (454)	44 (1118)	23 (584)	
XID-XIB 140	19 <sup>5</sup> / <sub>8</sub> (498)	28 <sup>7</sup> / <sub>8</sub> (714)	26 <sup>3</sup> / <sub>4</sub> (679)	19 <sup>7</sup> / <sub>8</sub> (505)	50 <sup>1</sup> / <sub>16</sub> (1272)	28 (711)	
XID-XIB 160	23 <sup>1</sup> / <sub>2</sub> (597)	31 (787)	29 <sup>3</sup> / <sub>4</sub> (756)	22 <sup>7</sup> / <sub>8</sub> (581)	49 <sup>5</sup> / <sub>8</sub> (1260)	23 <sup>3</sup> / <sub>8</sub> (600)	Hanging rails not included. Supplied by others.
XIB 180	25 <sup>1</sup> / <sub>2</sub> (648)	33 <sup>1</sup> / <sub>2</sub> (851)	29 <sup>9</sup> / <sub>16</sub> (751)	22 <sup>3</sup> / <sub>4</sub> (578)	52 <sup>9</sup> / <sub>16</sub> (1335)	24 <sup>1</sup> / <sub>2</sub> (622)	
XIB 200	29 <sup>1</sup> / <sub>8</sub> (740)	37 (940)	33 <sup>3</sup> / <sub>4</sub> (857)	26 <sup>3</sup> / <sub>4</sub> (679)	64 <sup>3</sup> / <sub>16</sub> (1630)	32 <sup>1</sup> / <sub>4</sub> (819)	
XIB 240	31 <sup>1</sup> / <sub>8</sub> (803)	44 <sup>1</sup> / <sub>4</sub> (1124)	40 <sup>3</sup> / <sub>4</sub> (1035)	33 <sup>3</sup> / <sub>8</sub> (860)	66 <sup>1</sup> / <sub>2</sub> (1689)	32 <sup>1</sup> / <sub>8</sub> (816)	
XIB 300	35 (889)	51 (1295)	47 <sup>3</sup> / <sub>4</sub> (1213)	40 <sup>7</sup> / <sub>8</sub> (1038)	69 <sup>5</sup> / <sub>8</sub> (1756)	31 <sup>3</sup> / <sub>8</sub> (797)	
XIB 360	38 <sup>3</sup> / <sub>4</sub> (974)	57 <sup>1</sup> / <sub>4</sub> (1454)	53 <sup>1</sup> / <sub>2</sub> (1359)	46 <sup>3</sup> / <sub>4</sub> (1187)	76 (1930)	34 <sup>1</sup> / <sub>16</sub> (881)	
XIB 420	47 <sup>1</sup> / <sub>8</sub> (1197)	63 (1600)	59 <sup>7</sup> / <sub>8</sub> (1521)	59 <sup>7</sup> / <sub>8</sub> (1521)	90 <sup>1</sup> / <sub>2</sub> (2299)	40 <sup>1</sup> / <sub>2</sub> (1029)	

All dimensions in inches (millimeters).

# Redesigned XIB Dimensions

## Mounting: XIB

All XIB fan models can be mounted horizontally, vertically or at an angle. For ease of installation, knockouts are provided at each location where mounting brackets are shown in Figures 5, 6 and 7. Optional brackets are universally adjustable to mount in any of these locations.

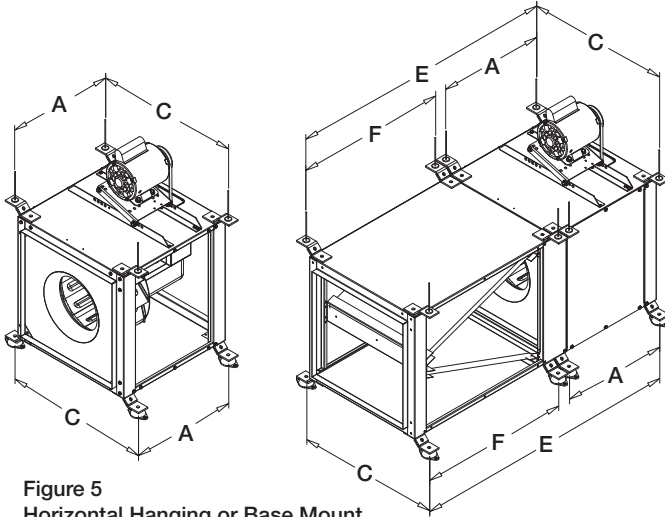

Figure 5  
Horizontal Hanging or Base Mount

With either a hanging or base mount the motor may be located on either side. The base mount allows top access panels only.

### NOTE

Flex duct is recommended for mounting to the inlet of the fan to allow for fitting adjustments.

If the inlet venturi requires adjustment, it can be detached from the unit via the fasteners located on the inlet panel.

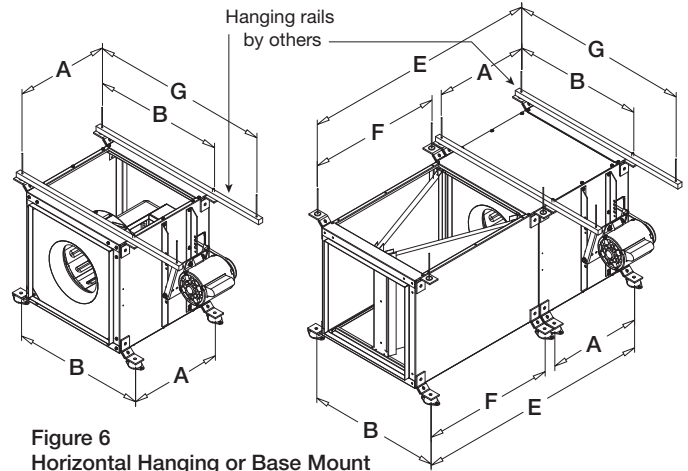

Figure 6  
Horizontal Hanging or Base Mount

With a hanging mount, the motor may be located on either top or bottom. The base mount allows top motor location only. Both options provide access panels on two sides.

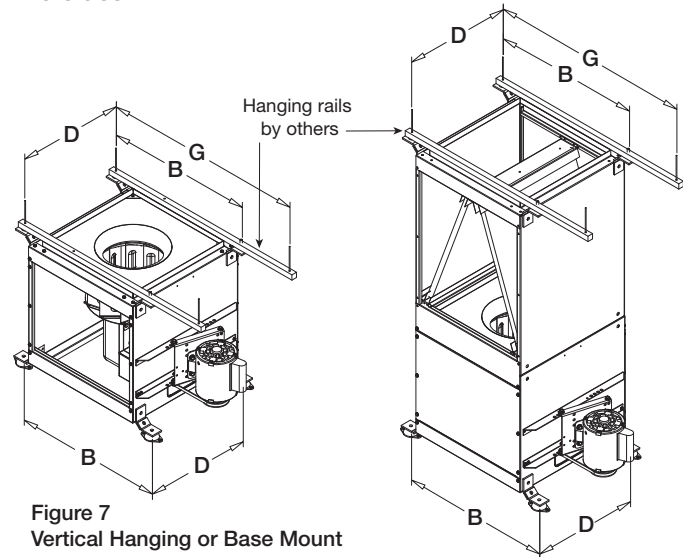

Figure 7  
Vertical Hanging or Base Mount

Mounting brackets are turned 90° for vertical mounting. Access panels are located on the two sides adjacent to the motor.

Mounting Dimensional Data							
Model	A	B	C	D	E	F	G
XIB 70-100	18 (457)	21 <sup>13</sup> / <sub>16</sub> (554)	19 <sup>14</sup> / <sub>16</sub> (505)	14 <sup>1</sup> / <sub>8</sub> (359)	50 <sup>14</sup> / <sub>16</sub> (1292)	29 <sup>14</sup> / <sub>16</sub> (758)	Hanging rails not included. Supplied by others.
XIB 120	18 (457)	23 <sup>13</sup> / <sub>16</sub> (605)	21 <sup>14</sup> / <sub>16</sub> (556)	16 <sup>1</sup> / <sub>8</sub> (410)	55 <sup>3</sup> / <sub>4</sub> (1416)	34 <sup>3</sup> / <sub>4</sub> (883)	
XIB 130	18 (457)	25 <sup>13</sup> / <sub>16</sub> (656)	23 <sup>14</sup> / <sub>16</sub> (607)	18 <sup>1</sup> / <sub>8</sub> (460)	50 <sup>1</sup> / <sub>4</sub> (1276)	29 <sup>1</sup> / <sub>4</sub> (743)	Hanging rails not included. Supplied by others.
XIB 140	19 (483)	27 <sup>13</sup> / <sub>16</sub> (707)	25 <sup>14</sup> / <sub>16</sub> (657)	20 <sup>1</sup> / <sub>8</sub> (511)	56 (1424)	34 (865)	
XIB 160	23 (584)	31 <sup>1</sup> / <sub>16</sub> (792)	29 (737)	23 <sup>1</sup> / <sub>8</sub> (587)	55 <sup>3</sup> / <sub>4</sub> (1416)	29 <sup>3</sup> / <sub>4</sub> (756)	Hanging rails not included. Supplied by others.
XIB 180	25 (635)	32 <sup>3</sup> / <sub>16</sub> (817)	30 (762)	24 <sup>1</sup> / <sub>8</sub> (613)	57 <sup>3</sup> / <sub>4</sub> (1467)	29 <sup>3</sup> / <sub>4</sub> (756)	
XIB 200	29 (737)	36 <sup>3</sup> / <sub>16</sub> (919)	34 (864)	28 <sup>1</sup> / <sub>8</sub> (714)	66 <sup>3</sup> / <sub>8</sub> (1686)	34 <sup>3</sup> / <sub>8</sub> (873)	Hanging rails not included. Supplied by others.
XIB 240	31 (787)	43 <sup>3</sup> / <sub>16</sub> (1097)	41 (1042)	35 <sup>1</sup> / <sub>8</sub> (892)	68 <sup>1</sup> / <sub>2</sub> (1740)	34 <sup>1</sup> / <sub>2</sub> (876)	

All dimensions in inches (millimeters).

**Duct Length:** The inlet and outlet duct length should be approximately two to three wheel diameters long before and after the fan to achieve cataloged performance.

**Side Discharge:** Make sure discharge is orientated in the same direction as originally ordered, performance will change with different discharge positions. Refer to Figure 8 for proper side discharge definition and the Side Discharge chart for dimensions. Refer to the CAPS program or consult factory for performance corrections.

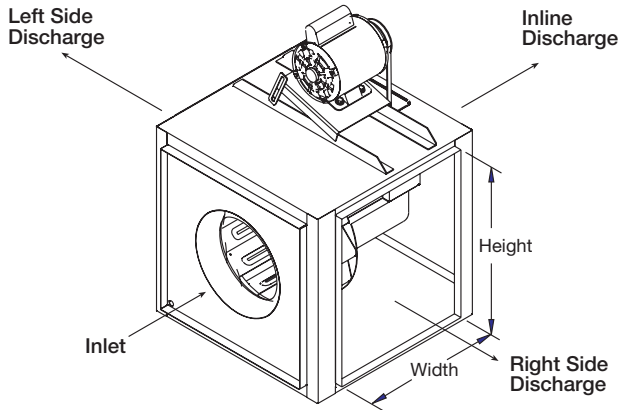
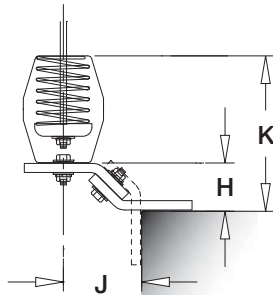
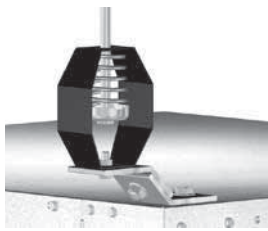

Figure 8

Side Discharge Duct Openings		
Unit Size	Width	Height
XIB 70-80-90	11 <sup>7</sup> / <sub>8</sub> (302)	11 <sup>7</sup> / <sub>8</sub> (302)
XID 60-75	9 <sup>7</sup> / <sub>8</sub> (251)	8 <sup>7</sup> / <sub>8</sub> (225)
XID 80-95	12 <sup>7</sup> / <sub>8</sub> (327)	11 <sup>7</sup> / <sub>8</sub> (302)
XID 100/XIB 100	13 <sup>7</sup> / <sub>8</sub> (352)	13 <sup>7</sup> / <sub>8</sub> (352)
XID 120/XIB 120	15 <sup>7</sup> / <sub>8</sub> (403)	15 <sup>7</sup> / <sub>8</sub> (403)
XID 130/XIB 130 (HP)	17 <sup>7</sup> / <sub>8</sub> (454)	17 <sup>7</sup> / <sub>8</sub> (454)
XID 140/XIB 140 (HP)	19 <sup>7</sup> / <sub>8</sub> (505)	19 <sup>7</sup> / <sub>8</sub> (505)
XID 160/XIB 160 (HP)	22 <sup>7</sup> / <sub>8</sub> (581)	22 <sup>7</sup> / <sub>8</sub> (581)
XIB 180 (HP)	23 <sup>7</sup> / <sub>8</sub> (606)	23 <sup>7</sup> / <sub>8</sub> (606)
XIB 200 (HP)	27 <sup>7</sup> / <sub>8</sub> (708)	27 <sup>7</sup> / <sub>8</sub> (708)
XIB 240 (HP)	28 <sup>7</sup> / <sub>8</sub> (733)	34 <sup>7</sup> / <sub>8</sub> (886)
XIB 300 (HP)	31 <sup>7</sup> / <sub>8</sub> (810)	41 <sup>7</sup> / <sub>8</sub> (1064)
XIB 360 (HP)	32 <sup>7</sup> / <sub>8</sub> (835)	37 <sup>7</sup> / <sub>8</sub> (962)
XIB 420	34 <sup>7</sup> / <sub>8</sub> (886)	43 <sup>7</sup> / <sub>8</sub> (1114)

All dimensions in inches (millimeters).

### Hanging Spring Isolator



### Hanging Neoprene Isolator

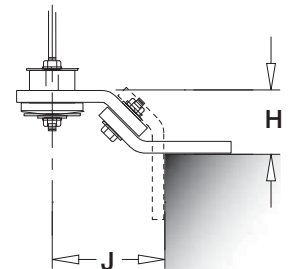
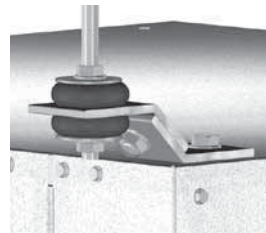

### Standing Neoprene Isolator

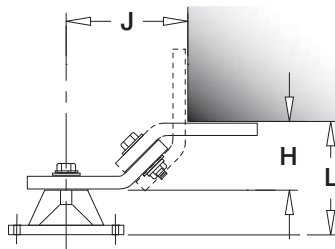

### Standing Spring Isolator

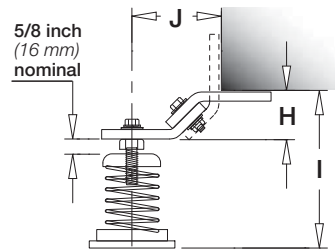

Isolator Dimensional Data					
Model	H	I	J	K	L
XID 60-75					
XID 80-95					
XIB 70-90	1 <sup>7</sup> / <sub>8</sub>	5 <sup>1</sup> / <sub>2</sub>	2	6 <sup>3</sup> / <sub>4</sub>	2 <sup>5</sup> / <sub>16</sub>
XID-XIB 100	(35)	(140)	(51)	(171)	(59)
XID-XIB 120					
XID-XIB 130					
XID-XIB 140					
XID-XIB 160					
XIB 180					
XIB 200					
XIB 240	1 <sup>7</sup> / <sub>8</sub>	5 <sup>1</sup> / <sub>2</sub>	2	6 <sup>3</sup> / <sub>4</sub>	2 <sup>5</sup> / <sub>8</sub>
XIB 300	(35)	(140)	(51)	(171)	(67)
XIB 360					
XIB 420					

All dimensions in inches (millimeters).



# Redesigned XIB Dimensions

Hanging Spring Isolator

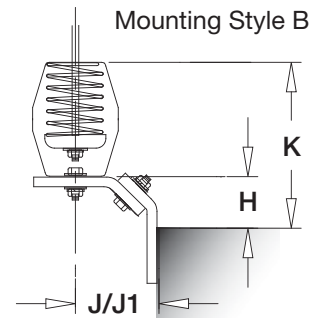
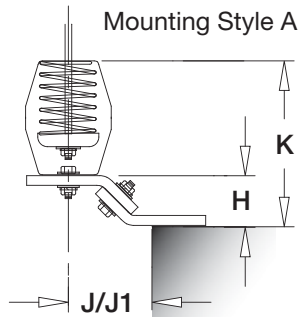
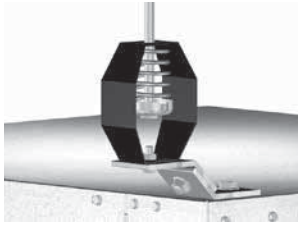

Hanging Neoprene Isolator

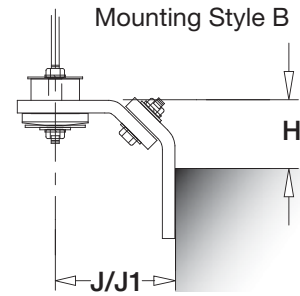
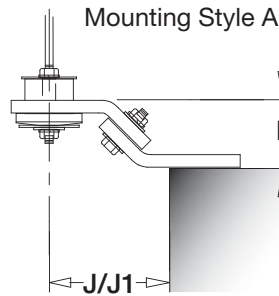
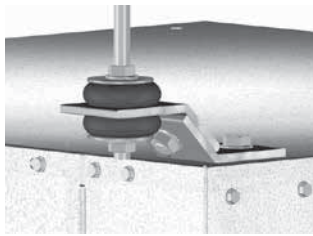

Standing Spring Isolator

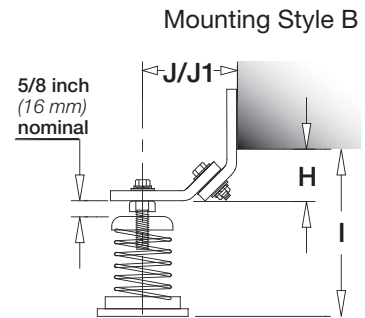
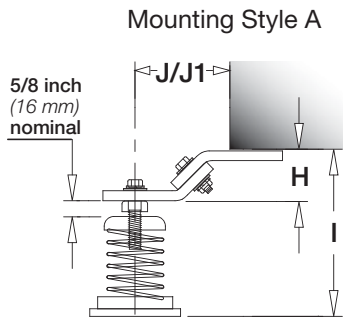

Standing Neoprene Isolator

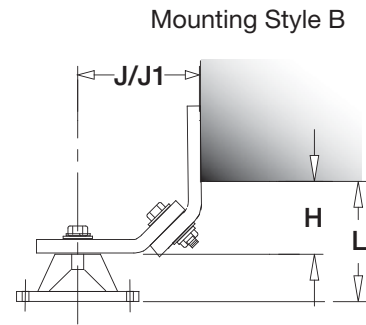
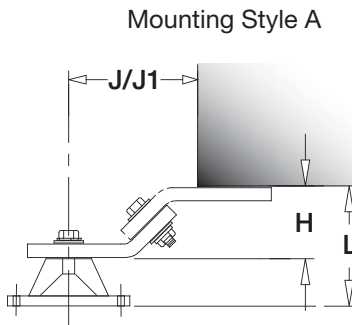

## Isolator Dimensional Data

Model	H	I	J*	J1**	K	L
XIB 70-90						
XIB 100						
XIB 120	1 <sup>3</sup> / <sub>8</sub>	5 <sup>1</sup> / <sub>2</sub>	1 <sup>3</sup> / <sub>8</sub>	2 <sup>3</sup> / <sub>8</sub>	6 <sup>3</sup> / <sub>4</sub>	2 <sup>1</sup> / <sub>3</sub>
XIB 130	(35)	(140)	(35)	(60)	(171)	(59)
XIB 140						
XIB 160						
XIB 180	1 <sup>3</sup> / <sub>8</sub>	5 <sup>1</sup> / <sub>2</sub>	1 <sup>3</sup> / <sub>8</sub>	2 <sup>1</sup> / <sub>2</sub>	6 <sup>3</sup> / <sub>4</sub>	2 <sup>5</sup> / <sub>8</sub>
XIB 200	(35)	(140)	(35)	(64)	(171)	(67)
XIB 240						

All dimensions in inches (millimeters).

\*Use dimension J while utilizing Mounting Style A

\*\*Use dimension J1 while utilizing Mounting Style B

# Redesigned XIB Dimensions

**Duct Length:** The inlet and outlet duct length should be approximately two to three wheel diameters long before and after the fan to achieve cataloged performance.

**Side Discharge:** Make sure discharge is orientated in the same direction as originally ordered, performance will change with different discharge positions. Refer to Figure 8 for proper side discharge definition and the Side Discharge chart for dimensions. Refer to the CAPS program or consult factory for performance corrections.

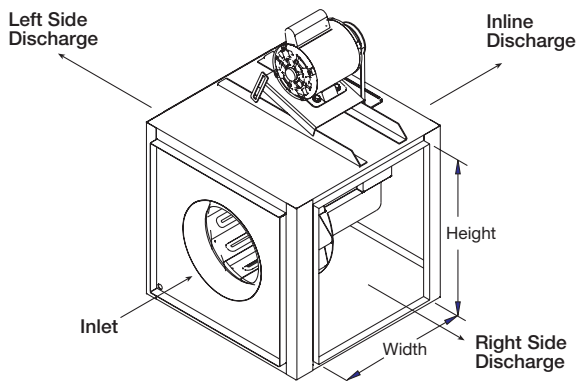

Figure 8

Side Discharge Duct Openings		
Unit Size	Width	Height
XIB 70-100	12½ (317)	13⅞ (352)
XIB 120	12½ (317)	15⅞ (403)
XIB 130 (HP)	12½ (317)	17⅞ (454)
XIB 140 (HP)	13½ (342)	19⅞ (505)
XIB 160 (HP)	17½ (444)	22⅞ (581)
XIB 180 (HP)	19½ (494)	23⅞ (606)
XIB 200 (HP)	23½ (596)	27⅞ (708)
XIB 240 (HP)	25½ (647)	34⅞ (886)

All dimensions in inches (millimeters).

## Pre Start-Up Checks

1. **Check all fasteners for tightness.** The wheel should rotate freely and be aligned as shown in Figure 9. Wheel position is preset and the unit is tested at the factory. Movement may occur during shipment, and realignment may be necessary. Centering can be accomplished by loosening the bolts holding the inlet (venturi) panel and repositioning. Wheel and inlet cone overlap can be adjusted by loosening the setscrews in the wheel and moving the wheel to the desired position.

### Wheel Overlap Dimensions

Model	G - Overlap in. (mm)	H - Gap in. (mm)
XID 60-95	-	1/8 (3)
XID 100-160	1/4 (6)	-
XIB 70-160	1/4 (6)	-
XIB 180-240	3/8 (10)	-
XIB 300-420	1/2 (13)	-

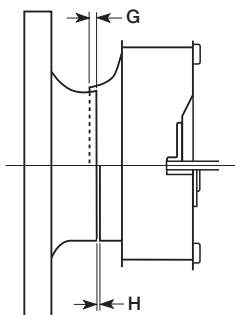

Figure 9

### 2. Wheel Rotation:

Direction of wheel rotation is critical. Reversed rotation will result in poor air performance, motor overloading and possible burnout. Check wheel rotation by momentarily energizing the unit (all XID and XIB fans

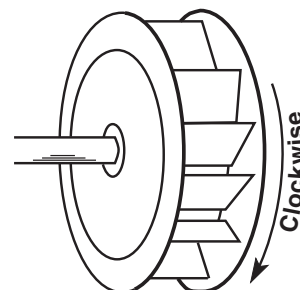

Figure 10

have clockwise wheel rotation when viewed from top of fan). Rotation should be clockwise as shown in Figure 10 and correspond to the rotation decal on the unit.

### WARNING

Correct direction of wheel rotation is critical. Reversed rotation will result in poor air performance, motor overloading and possible burnout.

### AVERTISSEMENT

La turbine doit impérativement tourner dans le bon sens. Une rotation en sens inverse entraînerait de mauvaises performances de soufflage, une surcharge du moteur voire un grillage du moteur.

3. **Vibration Isolators:** After fan is moved to desired location, punch out the four knockout holes which are located on the unit top and bottom panels. Assemble the brackets to the unit according to the appropriate drawings on pages 8 and 9 and refer to respective parts list on page 15. Make certain all connectors are tight and that all washers are in.

4. **For XIB Fans:** If adjustments are made, it is very important to check the pulleys for proper alignment. Misaligned pulleys lead to excessive belt wear, vibration, noise, and power loss. (see Figure 11 on next page).

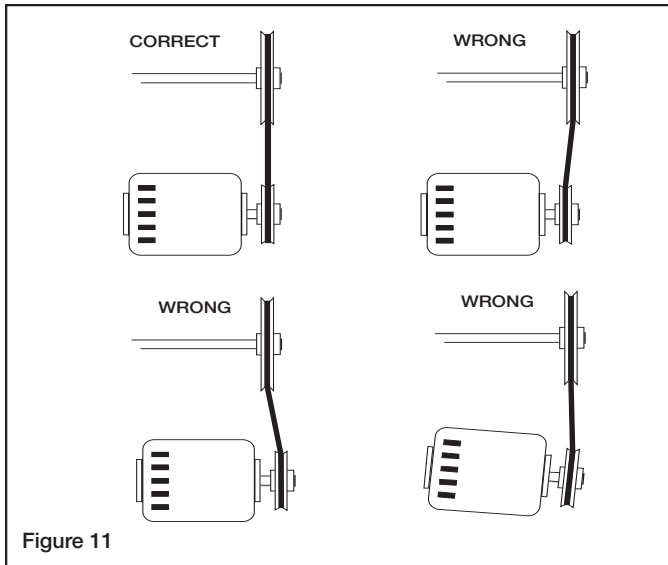

Figure 11

5. **For XIB Fans:** Belt tension can be adjusted by loosening four fasteners marked “R” on the drive frame. (refer to Figure 13). The motor plate slides on the slotted adjusting arms. Belt tension should be adjusted to allow 1/64 inch of deflection per inch of belt span. For example, a 15 inch belt span should have 15/64 inch (or about 1/4 inch) of deflection with moderate thumb pressure at mid-point between pulleys (see Figure 12). Over-tightening will cause excessive bearing wear and noise. Too little tension will cause slippage at start-up and uneven wear.

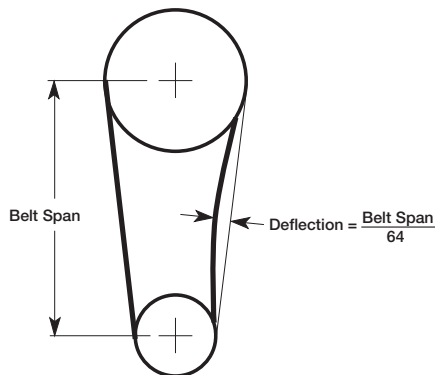

Figure 12

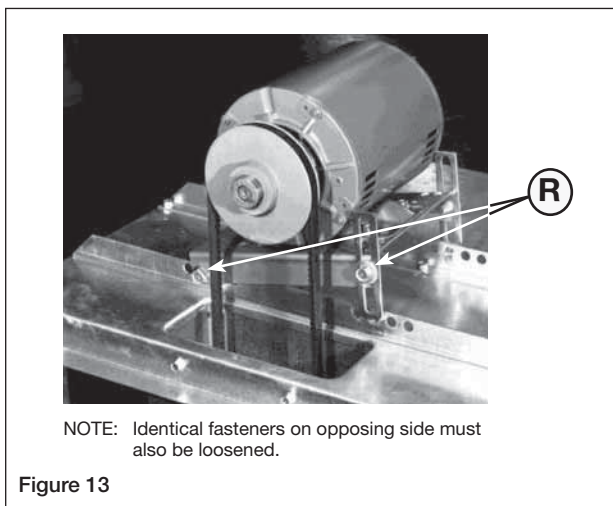

Figure 13

6. The adjustable motor pulley is factory set for the RPM specified. Speed can be increased by closing or decreased by opening the adjustable motor sheave. Two groove variable pitch pulleys must be adjusted an equal number of turns open or closed. Any increase in speed represents a substantial increase in the horsepower required by a unit. Motor amperage should always be checked to avoid serious damage to the motor when speed is varied.

### IMPORTANT

The fan has been checked for mechanical noises at the factory prior to shipment. If mechanical noise should develop, suggested corrective actions are offered in the Troubleshooting section.

### IMPORTANT

Over-tightening will cause excessive bearing wear and noise. Too little tension will cause slippage at start-up and uneven wear.

### IMPORTANT

Adjust (tighten) belt tension after the first 24-48 hours of operation.

### Operation: XID / XIB

1. Before starting up or operating fan, check all fasteners for tightness. In particular, check the setscrews in wheel hub (and pulleys, if applicable).
2. While in the OFF position or before connecting the fan to power, turn the fan wheel by hand to be sure it is not striking the venturi or any obstacle.
3. Start the fan and shut it off immediately to check rotation of the wheel with directional arrow in the motor compartment, see Figure 10.
4. When the fan is started, observe the operation and check for any unusual noises.
5. With the system in full operation and all ductwork attached, measure current input to the motor and compare with the nameplate rating to determine if the motor is operating under safe load conditions.
6. Keep inlets and approaches to fan clean and free from obstruction.

### Inspection: XID / XIB

Inspection of the fan should be conducted at the first 30 minute and 24 hour intervals of satisfactory operation.

#### 30 Minute Interval

Inspect bolts, setscrews and motor mounting bolts. Adjust and tighten as necessary.

#### 24 Hour Interval

Check all internal components. On XIB unit only, inspect belt alignment and tension. Adjust and tighten as necessary.

## Maintenance: XID / XIB

Installation and maintenance are to be performed only by qualified personnel who are familiar with local codes and regulations and who are experienced with this type of equipment.

Motor maintenance is generally limited to cleaning and lubrication (where applicable). Cleaning should be limited to exterior surfaces only. Removing dust buildup on motor housing ensures proper motor cooling.

Greasing of motors is only intended when fittings are provided. Many fractional horsepower motors are permanently lubricated and should not be lubricated after installation. Motors supplied with grease fittings should be greased in accordance with manufacturers' recommendations. Where motor temperatures do not exceed 104°F (40°C), the grease should be replaced after 2,000 hours of running time as a general rule.

Wheels require very little attention when moving clean air. Occasionally, oil and dust may accumulate causing imbalance. When this occurs the wheel and housing should be cleaned to ensure smooth and safe operation.

All fasteners should be checked for tightness each time maintenance checks are performed prior to restarting unit.

A proper maintenance program will help these units deliver years of dependable service.

<b>DANGER</b>
Always disconnect, lock and tag power source before servicing. Failure to disconnect power source can result in fire, shock or serious injury.
<b>DANGER</b>
Pour écarter les risques d'incendie, de choc électrique ou de blessure grave, veiller à toujours débrancher, verrouiller et étiqueter la source de courant avant l'installation ou l'entretien.
<b>IMPORTANT</b>
Uneven cleaning of the wheel will produce an out of balance condition that will cause vibration in the fan.
<b>WARNING</b>
This unit should be made non-functional when cleaning the wheel or housing (fuses removed, disconnect locked off).
<b>WARNING</b>
L'appareil doit être rendu non opérationnel lors du nettoyage de la turbine ou du caisson (fusibles retirés, sectionneur verrouillé).

## Belt/Bearing Maintenance XIB Unit

1. Belts tend to stretch after a period of time. They should be checked periodically for wear and tightness. When replacing belts, use the same type as supplied with the unit.
2. Matched belts should always be used on units with multi-groove pulleys.

3. For belt replacement, loosen the tensioning device enough to allow removal of the belt by hand. Do not force belts on or off. This may cause cords to break, leading to premature belt failure.
4. Once installed, adjust belts as shown in "Pre-Start-Up Checks."
5. Shaft bearings can be classified in two groups: relubricating and non-relubricating. All bearings on standard model XIB fans are factory lubricated and require no further lubrication under normal use (between -20°F and 180°F in a relatively clean environment).
6. Units installed in hot, humid or dirty locations should be equipped with special bearings. These bearings will require frequent lubrication. Caution should be employed to prevent overpacking or contamination.
7. Grease fittings should be wiped clean. The unit should be in operation while lubricating. Extreme care should be used around moving parts.
8. Grease should be pumped in very slowly until a slight bead forms around the seal. A high grade lithium base grease should be used.

## Recommended Relubrication Frequency in Months

NOTE: If unusual environment conditions exist (extreme temperature, moisture or contaminants) more frequent lubrication is required.

A good quality lithium base grease, conforming to NLGI Grade 2 consistency, such as those listed here may be used.

Suggested Fan Bearing Greasing Intervals	
Interval (months)	Type of Service
1 to 3	Heavy duty in dirty, dusty locations; high ambient temperatures; moisture laden atmosphere; vibration.
3 to 6	12 to 24 hours per day, heavy duty, or if moisture is present
6 to 12	8 to 16 hours per day in clean, relatively dry atmosphere
12 to 18	Infrequent operation or light duty in clean atmosphere

Grease Manufacturers	
Manufacturer	Grease (NLGI #2)
U.S. Electric Motors	Grease No. 83343
Chevron U.S.A. Inc	Chevron SRI Grease #2
Mobil Oil Corporation	Mobilith
	Mobil 532
Texaco, Inc.	Premium BRB #2
	Texaco Multifak #2
Amoco Oil Co.	Rykon Premium #2
Exxon	Unirex N2
Shell	B Shell Alvania #2

# Maintenance Documentation

---

## Job Information

Job Name: \_\_\_\_\_  
Address: \_\_\_\_\_  
City: \_\_\_\_\_  
State: \_\_\_\_\_ Zip: \_\_\_\_\_  
Phone: \_\_\_\_\_  
Contact Person: \_\_\_\_\_

Service Organization: \_\_\_\_\_  
Address: \_\_\_\_\_  
City: \_\_\_\_\_  
State: \_\_\_\_\_ Zip: \_\_\_\_\_  
Phone: \_\_\_\_\_  
Work Done By: \_\_\_\_\_

## Nameplate Information Field Start-Up Documentation

Model: \_\_\_\_\_  
Volts: \_\_\_\_\_ Hertz: \_\_\_\_\_ Phase: \_\_\_\_\_  
Amps: \_\_\_\_\_ Mark: \_\_\_\_\_  
Supply hp: \_\_\_\_\_ Exhaust hp: \_\_\_\_\_  
Serial Number: \_\_\_\_\_  
Model Voltage: \_\_\_\_\_  
Motor Amperage: \_\_\_\_\_  
Fan RPM: \_\_\_\_\_

Actual Voltage: \_\_\_\_\_ Hertz: \_\_\_\_\_ Phase: \_\_\_\_\_  
Actual Amperage: \_\_\_\_\_  
Blower Rotation: \_\_\_\_\_  
Air Volume: Design cfm: \_\_\_\_\_  
Actual cfm: \_\_\_\_\_  
Level of fan (L or H): \_\_\_\_\_  
Fan RPM Range (min.) \_\_\_\_\_ (max.) \_\_\_\_\_

# Maintenance Log

---

Date \_\_\_\_\_ Time \_\_\_\_\_ AM/PM  
Notes: \_\_\_\_\_  
\_\_\_\_\_  
\_\_\_\_\_

Date \_\_\_\_\_ Time \_\_\_\_\_ AM/PM  
Notes: \_\_\_\_\_  
\_\_\_\_\_  
\_\_\_\_\_

Date \_\_\_\_\_ Time \_\_\_\_\_ AM/PM  
Notes: \_\_\_\_\_  
\_\_\_\_\_  
\_\_\_\_\_

Date \_\_\_\_\_ Time \_\_\_\_\_ AM/PM  
Notes: \_\_\_\_\_  
\_\_\_\_\_  
\_\_\_\_\_

Date \_\_\_\_\_ Time \_\_\_\_\_ AM/PM  
Notes: \_\_\_\_\_  
\_\_\_\_\_  
\_\_\_\_\_

Date \_\_\_\_\_ Time \_\_\_\_\_ AM/PM  
Notes: \_\_\_\_\_  
\_\_\_\_\_  
\_\_\_\_\_

Date \_\_\_\_\_ Time \_\_\_\_\_ AM/PM  
Notes: \_\_\_\_\_  
\_\_\_\_\_  
\_\_\_\_\_

Date \_\_\_\_\_ Time \_\_\_\_\_ AM/PM  
Notes: \_\_\_\_\_  
\_\_\_\_\_  
\_\_\_\_\_

# Parts List

Each fan bears a manufacturer's nameplate with model number and serial number embossed. This information will assist the local Larkin representative and the factory in providing service and replacement parts. Before taking any corrective action, make certain unit is not capable of operation during repairs.

**CAUTION**  
 A fan manufactured with an explosion resistant motor does not certify the entire unit to be explosion proof. Refer to UL Listing Mark for the fans approved usage.

**CAUTION**  
 La présence d'un moteur antidéflagrant sur un ventilateur ne garantit pas que tout l'appareil est antidéflagrant. Pour connaître les emplois autorisés de l'appareil, voir son marquage de conformité UL.

## XID Direct Drive Centrifugal Inline Exhaust Fan

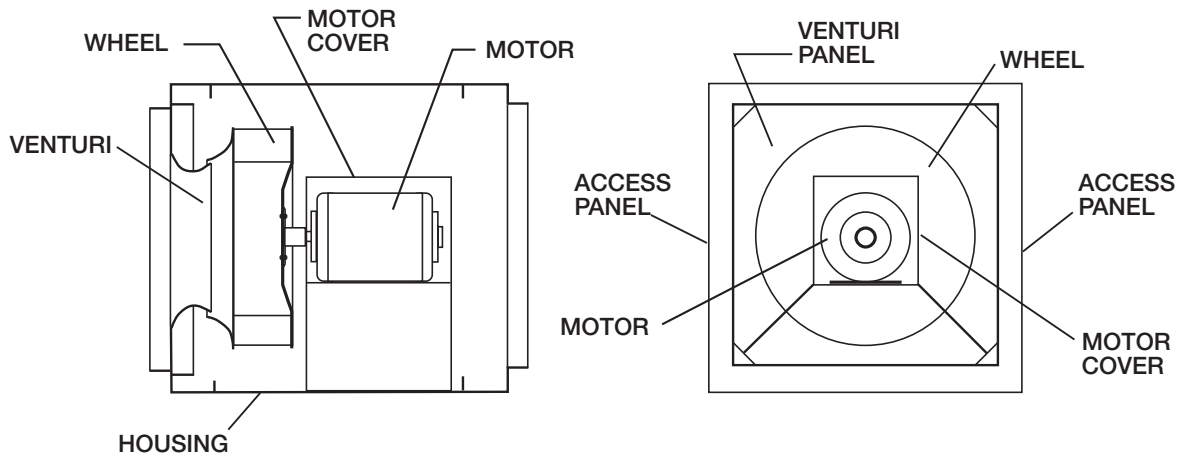

## XIB Belt Drive Centrifugal Inline Exhaust Fan

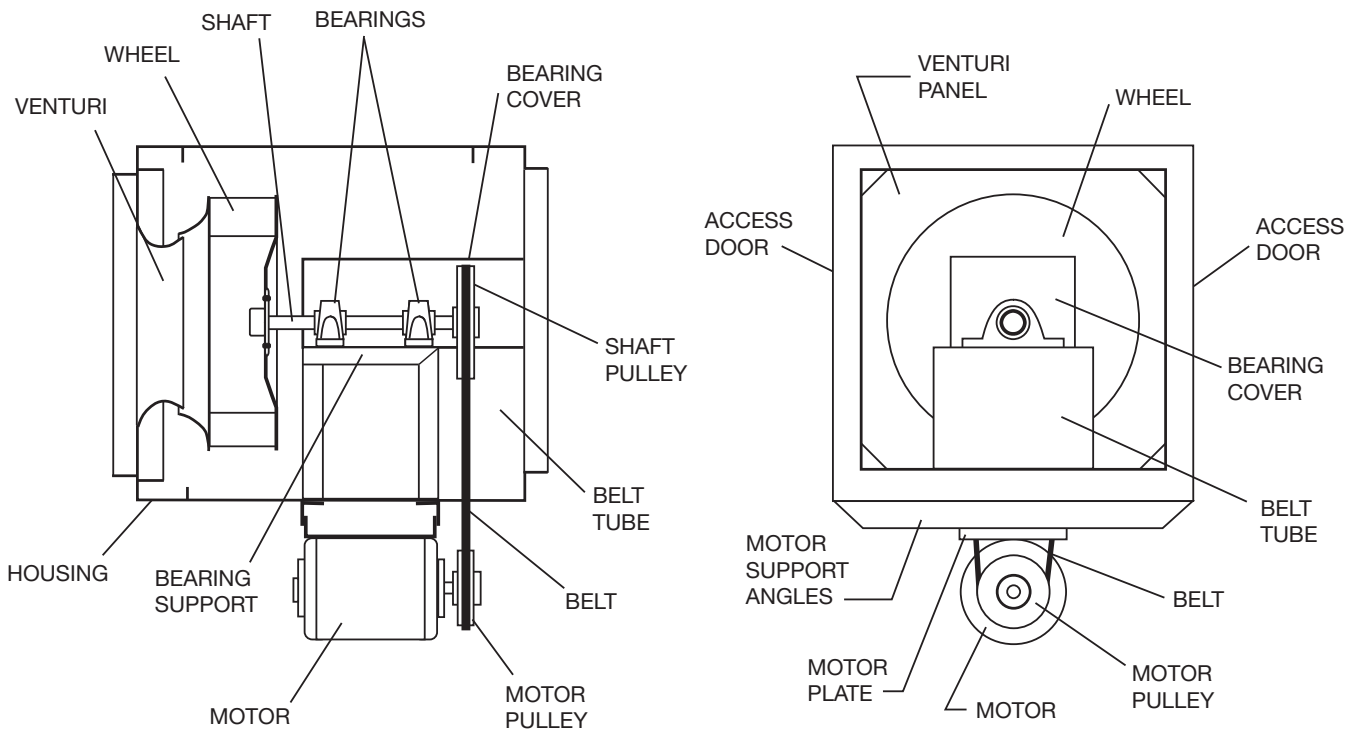

# Isolator Parts List

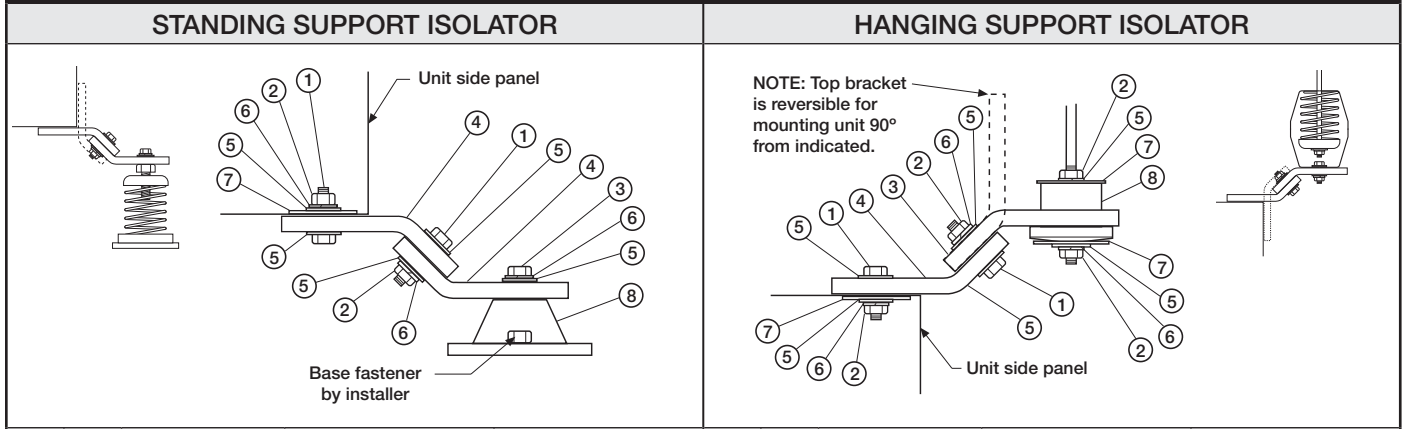

No.	Qty.	Description	XID-60 thru 140 XIB-100 thru 140	XID-160 XIB-160 thru 420	No.	Qty.	Description	XID-60 thru 140 XIB-100 thru 140	XID-160 XIB-160 thru 420
1	8	Cadium plated hex head bolts	3/8 in. - 16 x 1 in.	3/8 in.-16 x 1 1/4 in.	1	8	Cadium plated hex head bolts	3/8 in. - 16 x 1 in.	3/8 in.-16 x 1 1/4 in.
2	8	Cadium plated hex nuts	3/8 in. - 16	3/8 in. - 16	2	16	Cadium plated hex nuts	3/8 in. - 16	3/8 in. - 16
3	4	Cadium plated hex head bolts	5/16 in. - 18 x 1 in.	3/8 in. - 16 x 1 in.	3	4	Std. mount bracket with (1) 1/4 in. hole	3/16 in.	1/4 in.
4	8	Std. mount bracket with (2) 7/16 in. holes	3/16 in.	1/4 in.	4	4	Std. mount bracket with (2) 7/16 in. holes	3/16 in.	1/4 in.
5	20	Cadium plated washer	7/8 in. O.D. x 3/8 in. I.D. x 1/16 in.	7/8 in. O.D. x 3/8 in. I.D. x 1/16 in.	5	24	Cadium plated washer	7/8 in. O.D. x 3/8 in. I.D. x 1/16 in.	7/8 in. O.D. x 3/8 in. I.D. x 1/16 in.
6	12	Cadium plated lock washer	3/8 in.	3/8 in.	6	12	Cadium plated lock washer	3/8 in.	3/8 in.
7	4	Cadium plated washer	1 3/8 in. O.D. x 9/16 in. I.D. x 3/32 in.	1 3/8 in. O.D. x 9/16 in. I.D. x 3/32 in.	7	12	Cadium plated washer	1 3/8 in. O.D. x 9/16 in. I.D. x 3/32 in.	1 3/8 in. O.D. x 9/16 in. I.D. x 3/32 in.
8	4	Neoprene or Spring Isolator	Reference appropriate table below for replacement Isolator(s)		8	4	Neoprene or Spring Isolator	Reference appropriate table below for replacement Isolator(s)	

REPLACEMENT SPRING ISOLATOR(S)						
MODEL	FAN SIZES					
XIB	----	70-130	140-180	200	240-300	360-420
XID	60-100	120-140	160	----	----	----
BASE MOUNT	FDS-1-35 BLUE	FDS-1-70 GREEN	FDS 1-120 GRAY	FDS 1-120 GRAY	FDS-1-220 BROWN	FDS-1-370 ORANGE
HANGING	SH-1-35 BLUE	SH-1-70 GREEN	SH-1-125 GRAY	SH-1-245 BROWN	SH-1-245 BROWN	SH-1-370 ORANGE

REPLACEMENT NEOPRENE ISOLATOR(S)			
MODEL	FAN SIZE		
XIB	70-140	160-200	240-420
XID	60-140	160	----
BASE MOUNT	R-1 GREEN	R-2 BLACK	R-2 RED
HANGING	40DUR BLACK	50DUR BLACK	50DUR BLACK

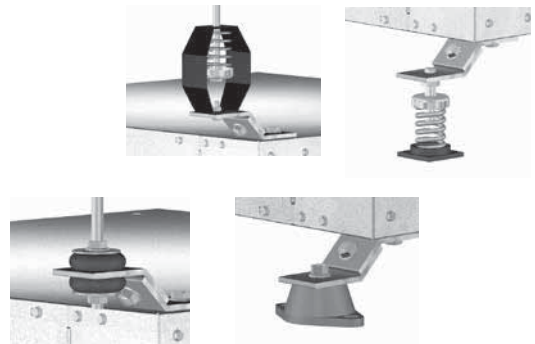

## Troubleshooting

### WARNING

Before taking any corrective action, make certain unit is not capable of operation during repairs.

### AVERTISSEMENT

Avant d'entreprendre toute action corrective, s'assurer que l'appareil ne pourra pas fonctionner durant les réparations.

PROBLEM	CAUSE	CORRECTIVE ACTION
Excessive noise or vibration	Wheel unbalance	Clean all dirt off wheel. Check wheel balance, rebalance in place if necessary.
	Bad bearings	Replace.
	Belts too tight or too loose	Adjust tension, see Figure 12.
	Wheel improperly aligned and rubbing	Center wheel on inlet, see Figure 9.
	Loose drive or motor pulleys	Align and tighten. See "Pre Start-Up Checks", see page 10-11.
	Foreign objects in wheel or housing	Remove objects, check for damage or unbalance.
Reduced airflow	System resistance too high	Check system: Proper operation of backdraft or control dampers, obstruction in ductwork, clean dirty filters.
	Unit running backwards	Correct as shown in Figure 10.
	Excessive dirt buildup on wheels	Clean wheel.
	Improper wheel alignment	Center wheel on inlets, see Pre Start-Up Checks and Figure 9.

## Our Commitment

*As a result of our commitment to continuous improvement, Accurex reserves the right to change specifications without notice.*

Specific Accurex product warranties are located on [accurex.com](http://accurex.com) within the product area tabs and in the Library under Warranty.



Larkin Industries, Inc.  
 114 David Green Rd., Birmingham, AL 35244  
 Phone: 1.800.322.4036 Fax: 1.205.987.0583  
 Email: [Sales@larkinhoods.com](mailto:Sales@larkinhoods.com)