

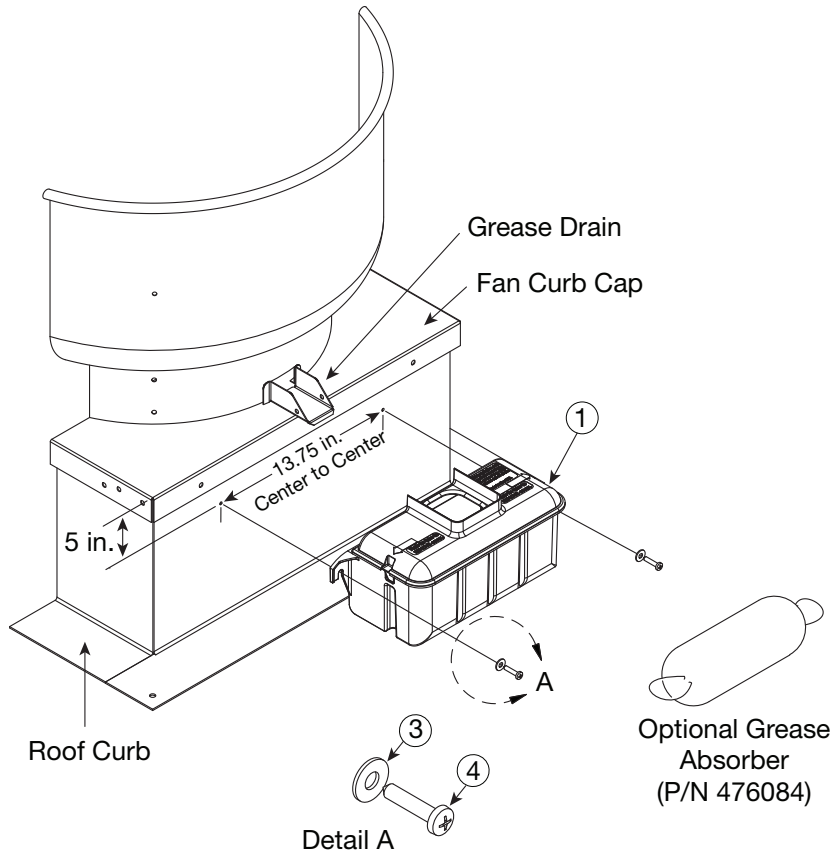

Installation, Operation and Maintenance Manual

Please read and save these instructions for future reference. Read carefully before attempting to assemble, install, operate or maintain the product described. Protect yourself and others by observing all safety information. Failure to comply with instructions could result in personal injury and/or property damage!



Parts List (per diagram)		
Number	Description	Quantity
1	Grease Trap Assm. without Absorber (475538)	1
2	** Grease Trap Assm. with Absorber (476085)	1
3	Flat Washer 1/4-inch x 0.75-inch	2
4	Sheet Metal Screw 1/4-inch x 0.75-inch	2

**This item not shown on drawing (grease trap assembly with absorber)

General Safety Information

Follow all local codes, as well as the National Fire Protection Agency (NFPA), where applicable.

NFPA 96: Upblast fans shall have a drain directed to a readily accessible and visible grease receptacle not to exceed 3.8 L (1 gal.)

Installation on Roof Curb

1. Install grease absorber in grease trap (if included) then snap cover into grease trap.
2. Locate and mark the container mounting holes on the extended base or roof curb.
3. Drill 3/16-inch diameter holes in the curb at the marked locations as shown.
4. Attach container with the two supplied 1/4-inch x 0.75-inch sheet metal fasteners. See detail "A". If extended base is a vented type, allow vent projections to hold trap away from curb.
5. Fill container with water (after installation and after each cleaning) until it flows out the drain hole. The water will not affect the grease absorbers performance. The unit is now ready for use.
6. Check grease absorber (if included) every month. Replace grease absorber after every cleaning and/or as needed between cleanings. Grease absorber safely holds a 1/2 gallon of grease.
7. Replacement grease absorbers (P/N 476084) can be ordered from your Larkin Representative.

Grease Trap Installation on Hinged Base

1. Locate two welded nut inserts on the lower portion of the hinged base as shown in the figure. Holes may be located on either the front or hinge side of the hinged base.
2. Insert two supplied 1/4-20 x 5/8-inch phillips truss head screws into nut inserts and start the threads.
3. Position grease trap hooks over the screws and tighten.

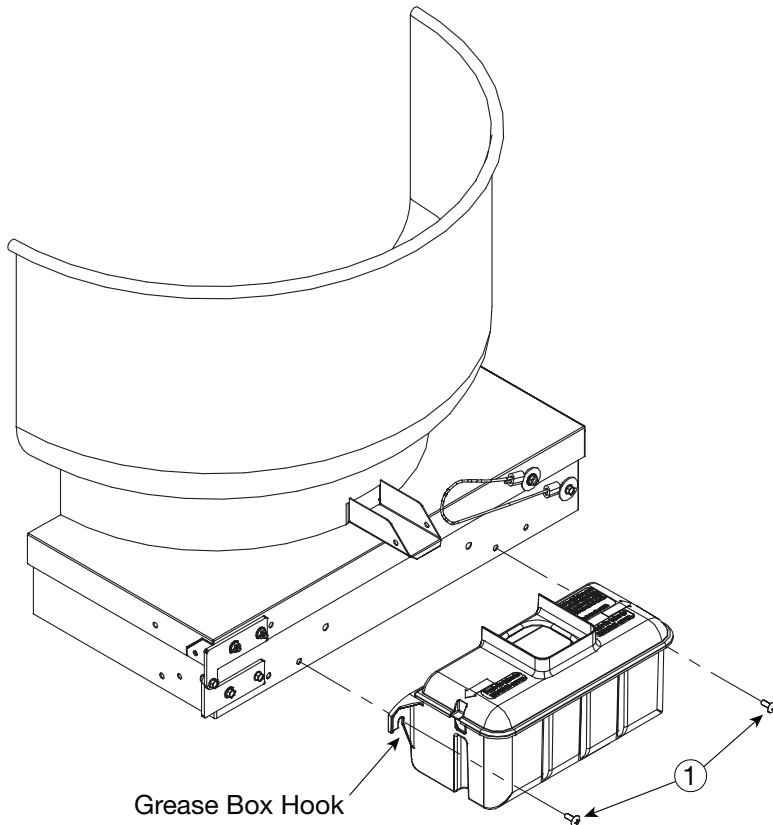

Parts List (per diagram)

Number	Description	Quantity
1	1/4-20 x 5/8 MS PTH (415729)	2

Polypropylene Grease Trap Material Properties

Property	Nominal Value (English)	Nominal Value (SI)
Operating Temperature Range	-40 to 200°F	-40 to 93°C
Melting Temperature Range	320 to 329°F	160 to 165°C
Impact Strength	9.0 ft-lb/in ²	19 kJ/m ²
UV Resistance	Min. 10 Year Life	Min. 10 Year Life
Flammability and Smoke	UL 94 Rated	UL 94 Rated



Larkin Industries, Inc.
 114 David Green Rd., Birmingham, AL 35244
 Phone: 1.800.322.4036 Fax: 1.205.987.0583
 Email: Sales@larkinhoods.com