

# Larkin®

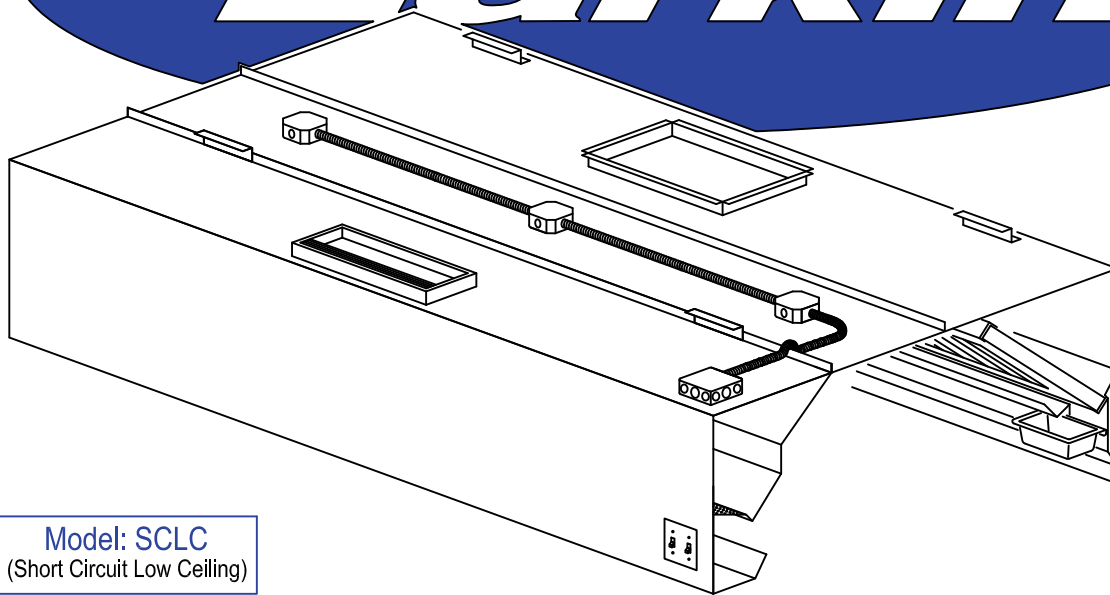

**Model: SCLC**  
(Short Circuit Low Ceiling)

## General Specifications:

Hood shall be self-compensating type introducing make-up air inside the hood through a full length, self-balancing slot. Hood shall be manufactured with a front height of 18" to 23" maintaining a typical hanging height of 78" from finished floor in low ceiling applications. The hood shall be fabricated from Type 430 stainless steel with #3 or #4 polish on all exposed surfaces. The supply plenum shall be lined with 1" thick 3 lb. density foil back insulation, with a flame spread rating of 25 or less as tested by UL 723 to impede condensation from forming on hood surfaces. Supply air plenum shall contain a balancing plate for even distribution of make-up air.

Hood shall be of double wall construction with seams and joints welded and sealed liquid tight, to conform to NFPA 96. Corners of hood shall be trimmed to give the hood a straight, crisp appearance free of warps. 12 gauge hanging brackets for hood shall be located on each corner (more brackets as needed for longer hoods). Grease filters shall be UL classified, non-clogging, baffle type. Filter size and quantity to extend the full length of hood and shall be easily removable for cleaning purposes.

All exhaust plenum surfaces and filters shall drain into a removable grease trough and be conveyed to a removable grease container for easy cleaning. Incandescent lights shall be installed at approximately 3' intervals and shall be UL listed for use in exhaust hoods and allow up to a 100 Watt standard light bulb. Lights shall be completely pre-wired to a junction box located on top of the hood. Exhaust collar shall have a 3/4" welding flange for easy field connection. Supply collar shall include a UL Listed fire damper.

Complete computer generated submittal drawings including material type, hood section view(s), plan view(s) and options chosen shall be provided. Duct sizes, CFM requirements and static pressures shall be shown on drawings. The hood shall be constructed in accordance with NFPA 96, bear the NSF Seal of Approval, and be ETL Listed. Hood to be manufactured by LARKIN INDUSTRIES, INC. 1-800-322-4036.

## Optional Features:

- Electrical controls/ Auto Fan Control System with Energy Saver
- Fire protection system
- Utility cabinet/ Fire cabinet
- Enclosure panels
- End panels
- Clearance reduction system
- Wall splash panels
- High Efficiency Vortex filters (1 or 2 stage)
- Fluorescent light fixtures

