

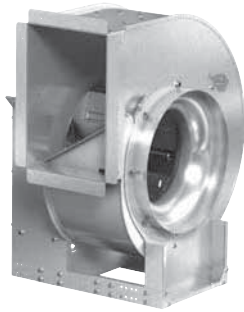

Installation, Operation and Maintenance Manual

Please read and save these instructions for future reference. Read carefully before attempting to assemble, install, operate or maintain the product described. Protect yourself and others by observing all safety information. Failure to comply with these instructions will result in voiding of the product warranty and may result in personal injury and/or property damage.



XUEFD-100



XUEF-100

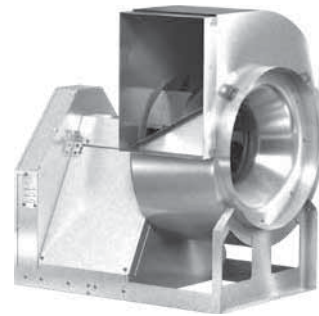

XUEF-200



XUEF-300



XUEF-400

General Safety Information

Only qualified personnel should install this fan. Personnel should have a clear understanding of these instructions and should be aware of general safety precautions. Improper installation can result in electric shock, possible injury due to coming in contact with moving parts, as well as other potential hazards. Other considerations may be required if seismic activity is present. If more information is needed, contact a licensed professional engineer before moving forward.

1. Follow all local electrical and safety codes, as well as the National Electrical Code (NEC) and the National Fire Protection Agency (NFPA), where applicable. Follow the Canadian Electric Code (CEC) in Canada.
2. The rotation of the wheel is critical. It must be free to rotate without striking or rubbing any stationary objects.
3. Motor must be securely and adequately grounded.
4. Do not spin fan wheel faster than max cataloged fan RPM. Adjustments to fan speed significantly effects motor load. If the fan RPM is changed, the motor current should be checked to make sure it is not exceeding the motor nameplate amps.
5. Do not allow the power cable to kink or come in contact with oil, grease, hot surfaces or chemicals. Replace cord immediately if damaged.
6. Verify that the power source is compatible with the equipment.
7. Never open access doors to a duct while the fan is running.

Receiving

Upon receiving the product, check to ensure all items are accounted for by referencing the delivery receipt or packing list. Inspect each crate or carton for shipping damage before accepting delivery. Alert the carrier of any damage detected. The customer will make a notation of damage (or shortage of items) on the delivery receipt and all copies of the bill of lading which is countersigned by the delivering carrier. If damaged, immediately contact your local representative. Any physical damage to the unit after acceptance is not the responsibility of manufacturer.

Unpacking

Verify that all required parts and the correct quantity of each item have been received. If any items are missing, report shortages to your local representative to arrange for obtaining missing parts. Sometimes it is not possible that all items for the unit be shipped together due to availability of transportation and truck space. Confirmation of shipment(s) must be limited to only items on the bill of lading.

Handling

Fans are to be rigged and moved by the lifting brackets provided or by the skid when a forklift is used. Location of brackets varies by model and size. Handle in such a manner as to keep from scratching or chipping the coating. Damaged finish may reduce the ability of the fan to resist corrosion. Fans should never be lifted by the shaft, fan housing, motor, belt guard, windband or accessories.

Storage

- Rotate fan wheel monthly and purge bearings once every three months.
- Energize fan motor once every three months.
- Store belts flat to keep them from warping and stretching.
- Store unit in a location which does not have vibration.
- After storage period, purge grease before putting fan into service.

If storage of fan is in a humid, dusty or corrosive atmosphere, rotate the fan and purge the bearings once a month. Improper storage which results in damage to the fan will void the warranty.

Fans are protected against damage during shipment. If the unit cannot be installed and operated immediately, precautions need to be taken to prevent deterioration of the unit during storage. The user assumes responsibility of the fan and accessories while in storage. The manufacturer will not be responsible for damage during storage. These suggestions are provided solely as a convenience to the user.

DANGER

Always disconnect, lock and tag power source before installing or servicing. Failure to disconnect power source can result in fire, shock or serious injury.

CAUTION

When servicing the fan, motor may be hot enough to cause pain or injury. Allow motor to cool before servicing.

CAUTION

Precaution should be taken in explosive atmospheres.

DANGER

Pour écarter les risques d'incendie, de choc électrique ou de blessure grave, veiller à toujours débrancher, verrouiller et étiqueter la source de courant avant l'installation ou l'entretien.

ATTENTION

Lors de toute intervention sur la soufflante, le moteur peut être suffisamment chaud pour provoquer une douleur voire une blessure. Laisser le moteur refroidir avant toute maintenance.

ATTENTION

Faire preuve de précaution dans les atmosphères explosives.

INDOOR - The ideal environment for the storage of fans and accessories is indoors, above grade, in a low humidity atmosphere which is sealed to prevent the entry of blowing dust, rain or snow. Temperatures should be evenly maintained between 30° to 110°F (-1° to 43°C), wide temperature swings may cause condensation and "sweating" of metal parts. All accessories must be stored indoors in a clean, dry atmosphere.

Remove any accumulations of dirt, water, ice, or snow and wipe dry before moving to indoor storage. To avoid "sweating" of metal parts allow cold parts to reach room temperature. To dry parts and packages use a portable electric heater to remove any moisture build up. Leave coverings loose to permit air circulation and to allow for periodic inspection.

The unit should be stored at least 3½ inches (89 mm) off the floor on wooden blocks covered with moisture proof paper or polyethylene sheathing. Aisles between parts and along all walls should be provided to permit air circulation and space for inspection.

OUTDOOR - Fans designed for outdoor applications may be stored outdoors, if absolutely necessary. Roads or aisles for portable cranes and hauling equipment are needed.

The fan should be placed on a level surface to prevent water from leaking into the fan. The fan should be elevated on an adequate number of wooden blocks so it is above water and snow levels and has enough blocking to prevent it from settling into soft ground.

Locate parts far enough apart to permit air circulation, sunlight and space for periodic inspection. To minimize water accumulation, place all fan parts on blocking supports so rain water will run off.

Do not cover parts with plastic film or tarps as these cause condensation of moisture from the air passing through heating and cooling cycles.

Fan wheels should be blocked to prevent spinning caused by strong winds.

Inspection and Maintenance During Storage

While in storage, inspect fans once per month. Keep a record of inspection and maintenance performed.

If moisture or dirt accumulations are found on parts, the source should be located and eliminated. At each inspection, rotate the wheel by hand ten to fifteen revolutions to distribute lubricant in motor and bearings. If paint deterioration begins, consideration should be given to touch-up or repainting. Fans with special coatings may require special techniques for touch-up or repair.

Machined parts coated with rust preventive should be restored to good condition promptly if signs of rust occur. Immediately remove the original rust preventive coating with petroleum solvent and clean with lint-free cloths. Polish any remaining rust from surface with crocus cloth or fine emery paper and oil. Do not destroy the continuity of the surfaces. Thoroughly wipe clean with Tectyl® 506 (Ashland Inc.) or the equivalent. For hard to reach internal surfaces or for occasional use, consider using Tectyl® 511M Rust Preventive, WD-40® or the equivalent.

Removing from Storage

As fans are removed from storage to be installed in their final location, they should be protected and maintained in a similar fashion until the fan equipment goes into operation.

Prior to assembly and installation of the unit and system components, inspect the fan assembly to make sure it is in working order.

1. Check all fasteners, set screws on the fan, wheel, bearings, drive, motor base and accessories for tightness.
2. Rotate the fan wheel by hand and assure no parts are rubbing. Access to the wheel is obtained through a bolted panel located on the side of the fan housing.
3. Ensure proper wheel settings for radial gap and alignment. Refer to Radial Gap, Overlap and Wheel Alignment section on page 10.

Table of Contents

General Safety Information	1
Receiving, Unpacking, Handling	2
Storage	2-3
Inspection and Maintenance During Storage	3
Removing from Storage	3
General Information	
Unit and System Identification Tags	4
Pre-Installation Information	4
Electrical Disconnects	4
Moving Parts	4
Guards - Motor Cover, Weatherhood, Shaft, Belt, Inlet or Outlet Guard	4
Access Doors	4
Air Pressure and Suction	4
Fans - Rigging and Lifting	4-6
Installation	
Discharge Positions	6
Ducted Inlet Installations	7
Ducted Outlet Installations	7
Non-Ducted Installations	7
Bases (Foundation and Isolation)	7
Fan Drainage Piping and Trap Detail	8
Electrical Connections	8
Electrical Disconnects and Moving Parts	8
UL/cUL 762 Listed Fans for Restaurant Exhaust	8
V-Belt Drives	
V-Belt Drive Installation	9
Alignment of Pulleys and Belts	9
Field Coating Touch-Up Procedure for Scratched Areas	9
Radial Gap, Overlap and Wheel Alignment	
Radial Gap and Alignment	10
Method for Centering Wheel	10
Wheel Rotation	10
Radial Gap and Overlap Dimensions	10
Unit Start-Up	
Visual Inspection of Equipment	11
Check	11
Additional Steps for Initial Start-Up	11
Model XUEFD-100-BI - Three-phase	11
Vibration	12
Routine Maintenance and Operation	
Fan Operation	12
Motors	12
Belt Drive Maintenance	13
XUEF-100 Belt Adjustment	13
Wheel and Fastener Maintenance	13
Bearing Lubrication Schedule	14
Variable Frequency Drive Operation	14
Model XUEFD-100-BI - Variable Speed Drives	14
Bearing Replacement	
Bearing Removal	15
Bearing Installation	15
Parts List	16-18
Troubleshooting	19
Maintenance Log	Backcover
Our Commitment	Backcover

General Information

To ensure a successful installation, the instructions in this manual should be read and adhered to. Failure to comply with proper installation procedures may void the warranty.

Unit and System Identification Tags

Each fan has a permanently affixed manufacturer's engraved metal nameplate containing the model number and individual serial number.

The tag shown is an example of an identification nameplate on the fan. The information provides general details about the fan, as well as containing specific information unique to the unit. When contacting your local manufacturer's

representative with future needs or questions, please have the information on this label available. Tags are mounted in an area which is clearly visible, usually on the side of the fan cabinet.



representative with future needs or questions, please have the information on this label available. Tags are mounted in an area which is clearly visible, usually on the side of the fan cabinet.

Pre-Installation Information

Before installation, it is important to be certain the mounting surface will bear the operating weight of the unit. For proper unit operation, it is also important that it be operated in a completely level position.

For further details on safety practices involving industrial and commercial fans, please refer to AMCA Publication 410.

Electrical Disconnects

All fan motors should have disconnects located in close visual proximity to turn off electrical service. Service disconnects shall be locked-out when maintenance is being performed.

NOTE

Models XUEF(D)-100-BI and XUEF-100-FC will include an integrated electrical disconnect.

Moving Parts

All moving parts must have guards to protect personnel. Refer to local codes for requirements as to the number, type and design. Fully secure fan wheel before performing any maintenance. The fan wheel may start "free wheeling" even if all electrical power has been disconnected. Before the initial start-up or any restart, check the following items to make sure that they are installed and secure.

- Do not spin fan wheel faster than the maximum cataloged fan RPM.
- Adjustments to fan speed significantly effects motor load. If the fan RPM is changed, the motor current should be checked to make sure it is not exceeding the motor nameplate amps.

Guards – Motor Cover, Weatherhood, Shaft, Belt, Inlet or Outlet Guard

Do not operate fans without proper protective devices in place. Failure to do so may result in serious bodily injury and property damage. Check local codes to ensure compliance for all protective devices.

Access Doors

Before opening access doors, ensure the fan wheel has stopped moving and that the wheel has been secured from being able to rotate. Do not operate fan without access door in its fully closed position.

Air Pressure and Suction

In addition to the usual hazards associated with rotating machinery, fans also create a dangerous suction at the inlet. Special caution needs to be used when moving around a fan, whether it is in operation or not. Before start-up, make sure the inlet area is clear of personnel and loose objects.

Fans – Rigging and Lifting

IMPORTANT

Fans should never be lifted by the shaft, motor, motor cover or accessories.

1. Before lifting, be sure that all shipping materials have been removed from the unit.
2. Use standard lifting and rigging practices.
3. ALL lifting brackets on each unit must be utilized at the same time.
4. Fan to be kept level during lifting and installation.
5. Spreader bars must span the unit to prevent damage to the unit by the lifting cables.
6. Always test-lift the unit to check for proper balance and rigging before hoisting to desired location.
7. Never lift unit in windy conditions.
8. Preparation of roof opening should be completed prior to lifting unit to the roof.

Fans are to be rigged and moved by the lifting brackets provided or by the skid when a forklift is used. Location of brackets varies by model and size. Handle in such a manner as to keep from scratching or chipping the coating. Damaged finish may reduce ability of fan to resist corrosion.

See coating repair section of this manual for details regarding touch-up of damaged surfaces.

IMPORTANT

Spreader bars are recommended to prevent damage to the unit. Failure to use spreader bars may result in damage which becomes the installer's responsibility.

NOTE

- Certain images are shown with higher lifting points on the unit. These are tie-off points to balance the load while lifting.
- Motor covers on certain size units and arrangements need to be removed prior to rigging and lifting as shown in diagram.

Sizes 4 thru 24

XUEF-100 Arrangement 10
Without Isolation Base

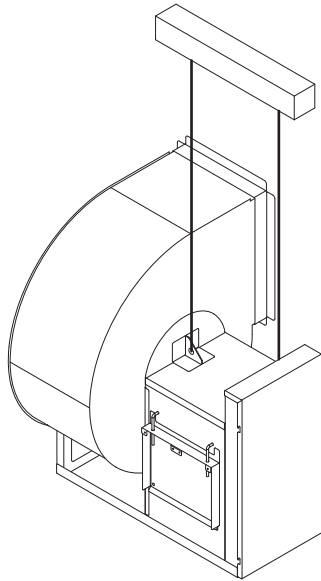

Sizes 7 thru 24

XUEFD-100, XUEF-200 and XUEF-300 Arrangement 10
Without Isolation Base

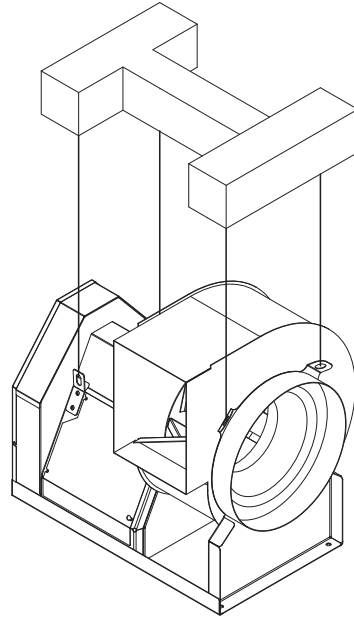

Optional Height Savings Bracket

For illustration purposes, some lifting location images with isolation bases are shown with optional height savings brackets. Lift unit using the corner hole located in the isolation base; with and without the height savings bracket.

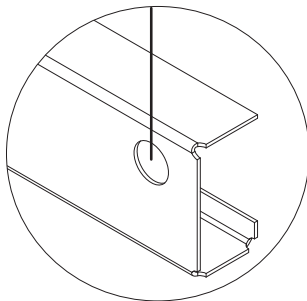

Isolation Base

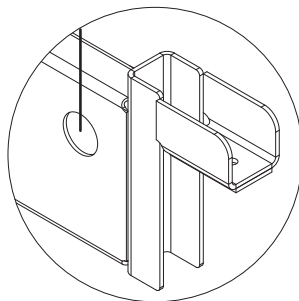

Isolation Base with
Height Savings Bracket

Sizes 27 thru 49

XUEF-300 Arrangement 10
Without Isolation Base

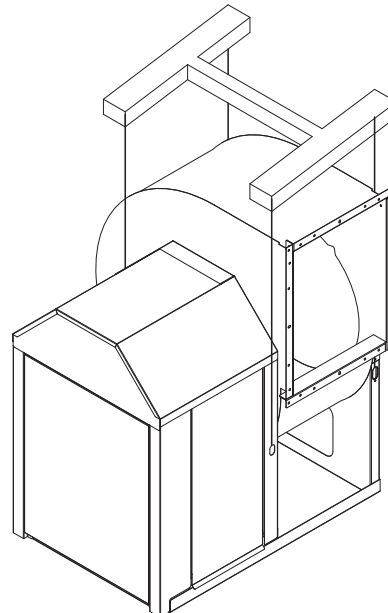

Sizes 7 thru 30

XUEF-400 Class 0, I, II, Arrangement 10 Without Isolation Base

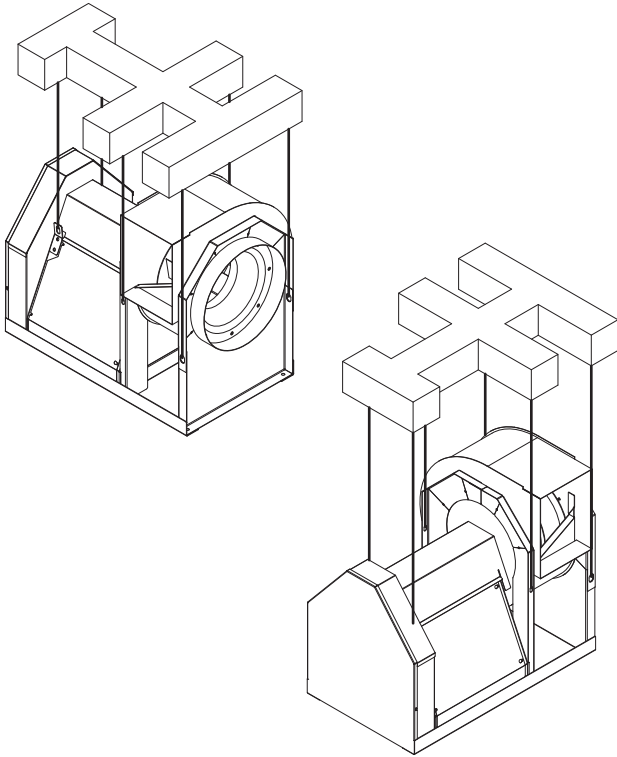

Sizes 33 thru 73

XUEF-400 Arrangement 10 Without Isolation Base

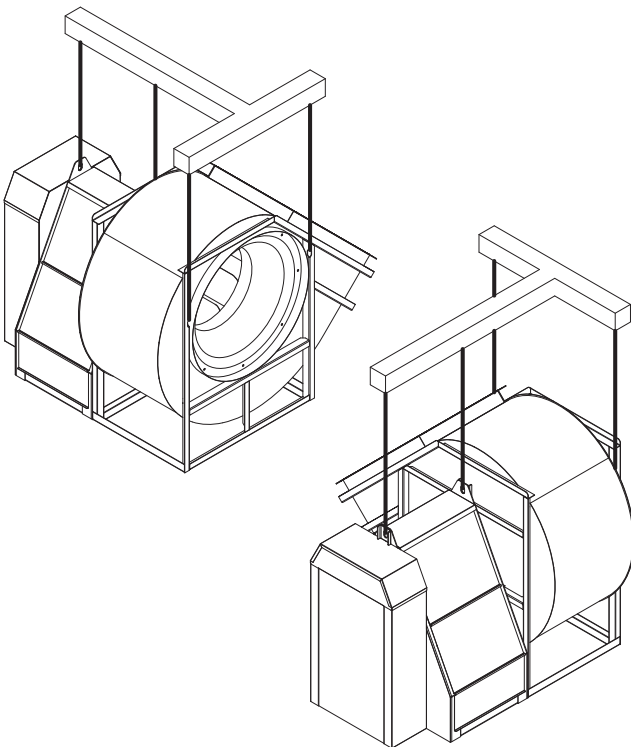

Installation

Move the fan to the desired location. Check and tighten fasteners throughout the unit and then fasten securely through mounting holes provided in the base angles. The unit must be set level (shimming may be necessary). Flexible duct connections and vibration isolators should be used where noise is a factor.

The motor voltage and ampere rating must be checked for compatibility with the electrical supply prior to final electrical connection. Supply wiring to the fan must be properly fused, and conform to local and national electrical codes.

Discharge Positions

XUEF(D)-100

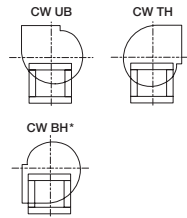

XUEF-200

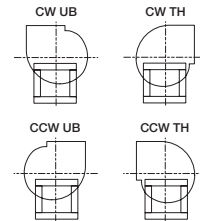

*Except XUEFD-100-BI

XUEF-300 and XUEF-400

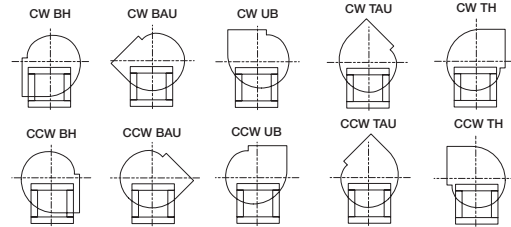

The discharge is factory set as specified by customer order, however, certain sizes can be rotated to other discharge positions in the field if necessary. If rotating the fan housing, accommodations may need to be made for the fan to drain properly. The XUEF(D)-100, XUEF-200, and XUEF-300, all sizes, have field rotatable housings. For the XUEF-400, rotatable housings are standard on sizes 30 and less, arrangement 10, and Class 0, I and II. Removal of the housing bolts allows the discharge to be rotated to the clockwise positions shown above. For downblast (DB) discharge position, a portion of the frame angle must be removed.

Fan rotation is always specified from the drive side of the housing.

Installations with inlet or discharge configurations that deviate from this manual may result in reduced fan performance. Restricted or unstable flow at the fan inlet can cause pre-rotation of incoming air or uneven loading of the fan wheel yielding large system losses and increased sound levels. Free discharge or turbulent flow in the discharge ductwork will also result in system effect losses. Refer to the following diagrams for the most efficient installation conditions.

Ducted Inlet Installations

Inlet Duct Turns - Installation of a duct turn or elbow too close to the fan inlet reduces fan performance because air is loaded unevenly into the fan wheel. To achieve full fan performance, there should be at least three fan wheel diameters between the turn or elbow and the fan inlet.

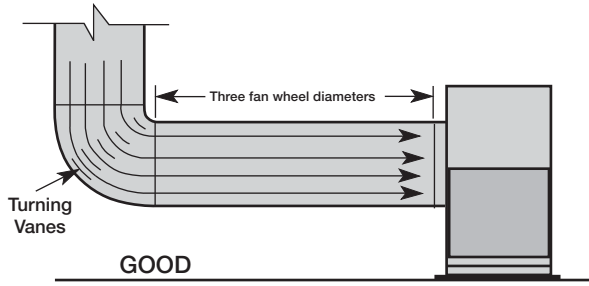
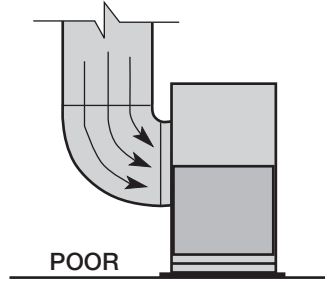

Inlet Spin - Inlet spin is a frequent cause of reduced fan performance. The change in fan performance is a function of the intensity of spin and not easily defined. The best solution is proper duct design and airflow patterns. Turning vanes reduce the effects of inlet spin.

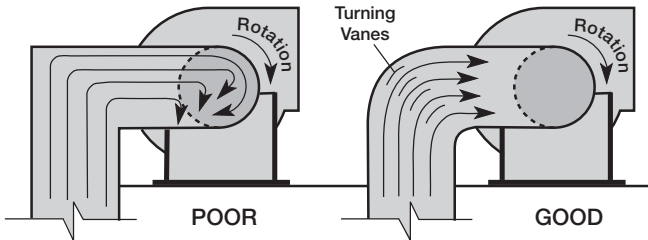

Ducted Outlet Installations

Discharge Duct Turns - Duct turns located near the fan discharge should always be in the direction of the fan rotation.

Fan performance is reduced when duct turns are made immediately off the fan discharge. To achieve cataloged fan performance there should be at least three equivalent duct diameters of straight ductwork between the fan discharge and any duct turns.

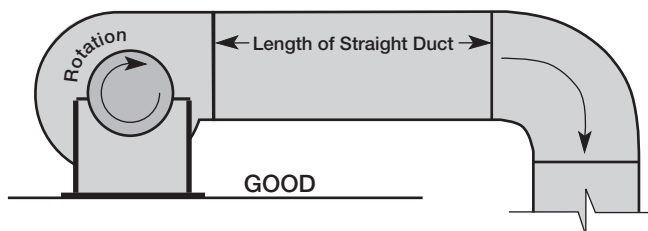
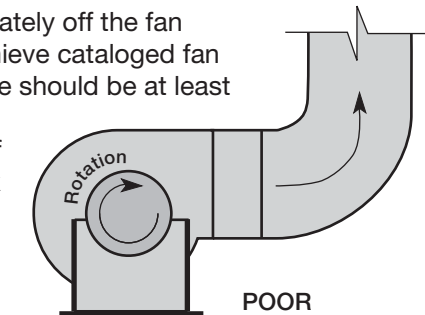

Non-Ducted Installations

Inlet Clearance - Installation of a fan with an open inlet too close to a wall or bulkhead will cause reduced fan performance. It is desirable to have a minimum of three-fourths of a wheel diameter between the fan inlet and the wall.

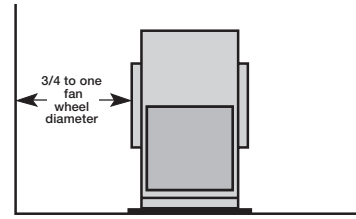

Single Fan Installation

Free Discharge - Free or abrupt discharge into a plenum results in a reduction in fan performance. The effect of discharge static regain is not realized.

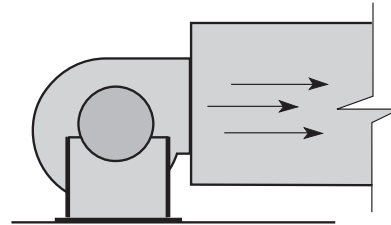

Bases (Foundation and Isolation)

Critical to every fan installation is a strong, level foundation. A reinforced poured concrete pad with a steel base or inertia base provides an excellent foundation. Bases must be sturdy enough, with welded construction, to prevent flexing and vibration.

To eliminate vibration and noise from being transferred to the building, vibration isolators should be used. The fan is mounted directly on the isolation base and must be supported for the entire length of the fan base angle. Isolators are installed between the isolation base and the foundation.

After the fan, isolation base, and isolators are installed, the entire assembly must be leveled. Position the level on the isolation base, not the fan shaft, for proper leveling. Additionally, the motor and fan shafts must be level and parallel relative to each other for proper alignment.

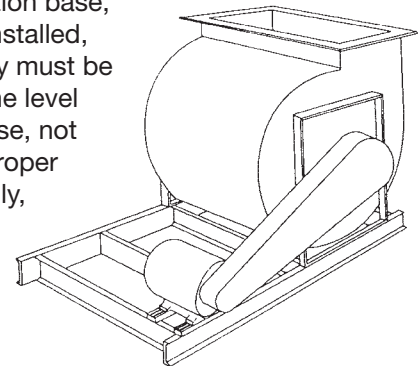

Typical Fan on Isolation Base

Fan Drainage Piping and Trap Detail (by others)

Fans may have been supplied with an optional drain. Drains are located at the underside of the scroll housing. The drain may need to be connected to a drainage system to ensure proper disposal of any water or condensate that may occur.

- Drain connections with a plug are 1.0 inch (25.4 mm) MNPT.
- Installed piping to have a downward angle to allow for drainage.
- Fill traps to recommended level before start-up.

Note: A conservative method of trap design is to set N = total static pressure.

Positive Pressure Trap

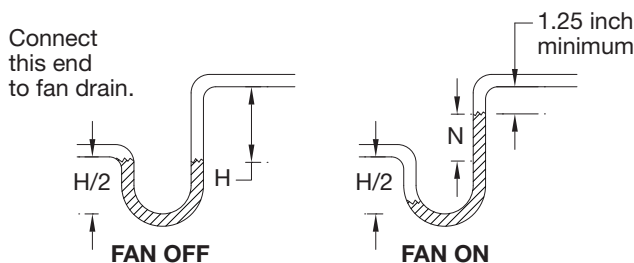

N = Negative fan pressure (inches W.C.)
 H = $N - 0.5$ inches minimum

Check local codes for proper disposal of drain water which has been in contact with the exhaust air.

Fans used for grease exhaust need to be equipped with a separate grease collector.

Drain Options	
XUEF(D)-100	Drain only*
XUEF-200	None Drain only* With plug
XUEF-300	None With plug
XUEF-400	None With plug

*1.0 inch (25.4 mm) non-threaded drain hole

Electrical Connections

Before electrical connections are made, the supply voltage, phase and ampere capacity must be checked for compatibility with the fan motor. In addition, the supply wiring must be properly fused and conform to local and national electrical codes. If the unit is supplied with a safety disconnect switch, ensure proper wiring to the fan motor. Be sure the disconnect is switched to the "OFF" position before connecting supply wires. If no disconnect is supplied, ensure the supply wire is not live before connection. Supply wires are then connected to the optional safety disconnect switch (if supplied) or motor.

IMPORTANT

When installing a fan, ensure the proper protective devices are used to protect personnel from moving parts and other hazards. A complete line of protective accessories are available from the manufacturer including: inlet guards, outlet guards, belt guards, shaft guards, protective cages and electrical disconnects.

Electrical Disconnects

All fan motors should have disconnects located in close visual proximity to turn off electrical service. Service disconnects shall be locked out when maintenance is being performed.

Moving Parts

All moving parts must have guards to protect personnel. Refer to local codes for requirements as to the number, type and design. Fully secure fan wheel before performing any maintenance. The fan wheel may start "free wheeling" even if all electrical power has been disconnected. Before the initial start-up or any restart, check the guards (belt, shaft, inlet and outlet) and check the access doors to ensure that they are installed and secure.

Installation of UL/cUL 762 Listed Fans for Restaurant Exhaust

The UL/cUL 762 listing for restaurant exhaust is available on the XUEF-300 and 400.

UL/cUL 762 fans are listed for a maximum operating temperature of 400°F (204°C) and includes an access door and 1 inch (25.4 mm) drain connection. An outlet guard is strongly recommended when the fan discharge is accessible. An upblast discharge is recommended. The fan discharge must be a minimum of 40 inches (1016 mm) above the roof line and the exhaust duct must be fully welded to a distance of 18 inches (457 mm) above the roof surface.

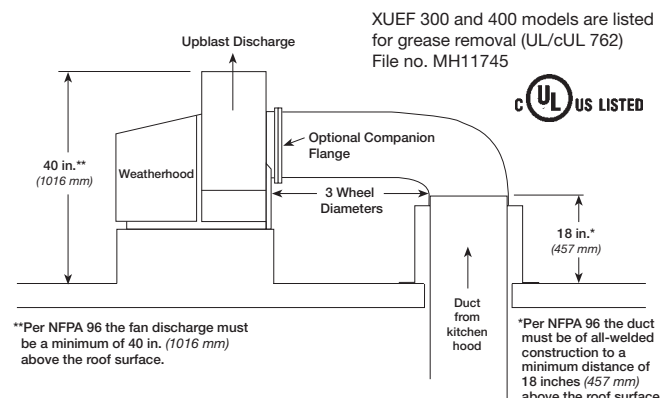

**Per NFPA 96 the fan discharge must be a minimum of 40 in. (1016 mm) above the roof surface.

**Per NFPA 96 the duct must be of all-welded construction to a minimum distance of 18 inches (457 mm) above the roof surface.

This drawing is for dimensional information only. See the latest edition of NFPA 96 Standard for Ventilation Control and Fire Protection of Commercial Cooking Operations for detailed installation instructions, materials, duct connections and clearances.

V-Belt Drives

V-Belt Drive Installation

1. Remove the protective coating from the end of the fan shaft using mineral spirits or another similar solvent. Check to ensure that the shaft is free of nicks and burrs.
2. Slide sheaves on shafts. Do not drive sheaves on as this may result in bearing damage.
3. Align fan and motor sheaves with a straight edge or string and tighten.
4. Place belts over sheaves. Do not pry or force belts, as this could result in damage to the cords in the belts.
5. Adjust the tension until the belts appear snug. Run the unit for a few minutes and allow the belts to "set" properly.
6. With the fan off and disconnect locked out, adjust the belt tension by moving the motor pivot plate. When in operation, the tight side of the belts should be in a straight line from sheave to sheave with a slight bow on the slack side.

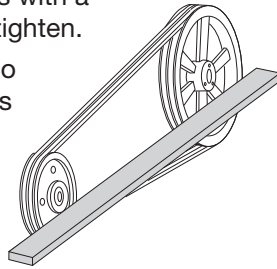

Aligning Sheaves with a Straight Edge

Alignment of Pulleys and Belts

Check pulleys and belts for proper alignment to avoid unnecessary belt wear, noise, vibration and power loss. Motor and drive shafts must be parallel and pulleys in line as shown in Figure 1.

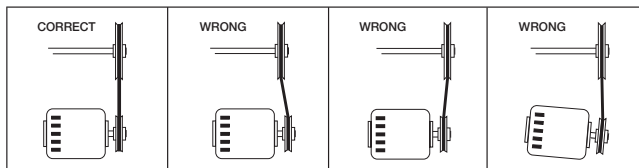

Figure 1

The adjustable motor pulley is set at the factory for the fan RPM specified by the customer. Fan RPM can be increased by closing or decreased by opening the adjustable motor pulley. Multigroove variable pitch pulleys must be adjusted an equal number of turns open or closed. Any increase in fan speed represents a substantial increase in load on the motor.

To avoid motor overheating and possible burnout, motor load amperes should always be checked and compared to nameplate rating when fan speed is increased.

Field Coating Touch-Up Procedure for Scratched Areas

Standard coating and color is RAL 7023 Concrete Grey. The procedure outlines the correct method for repairing minor scratches in the coating.

TOUCH-UP PAINT REPAIR KIT CONTENTS

- One pint of Kem Kromik® primer
 - including a technical data sheet
- One pint of industrial enamel
 - including a technical data sheet
- Four disposable foam brushes
- One sheet sandpaper
- Repair procedure details

1. Scuff affected area to be repaired using medium sandpaper (provided) or medium Scotch Brite™ pad. Feather the edges.
2. Clean affected area to be touched up using an alkaline based cleaner and rinse.
3. Apply Kem Kromik® primer using 1 inch foam brush (provided). Follow technical data sheet instructions.
4. Allow primer to dry a minimum of 2-1/2 hours before top coating.
5. Apply topcoat with industrial enamel using 1 inch foam brush (provided). Follow technical data sheets instructions. Allow painted units to air-dry and cure before putting into service. See Technical Data sheets (included with kit) for detailed drying and cure schedules at different temperatures.

NOTE

While the manufacturer provides heavy-duty, quality products for marine environments, routine paint touch-ups may be required in coastal regions where salt or marine air could damage the coating. The severe environment will accelerate the damage from any scratches or chips and it is recommended that those be repaired immediately.

To order additional coating repair kits please reference part number HAZ2597 PNT FIELD REPAIR KIT, RAL 7023 CONCRETE GREY. Please contact factory with your fan's serial number for colors other than our standard.

Radial Gap, Overlap and Wheel Alignment

Wheels must rotate freely and not rub on the inlet cone. Model XUEF(D)-BI (backward-inclined) wheels overlap the inlet cone. There is a gap between the inlet cone and wheel on model XUEF(D)-FC (forward-inclined). Refer to the tables for the proper dimension.

Radial Gap and Alignment

Efficient fan performance can be maintained by having the correct radial gap, overlap and wheel alignment. These items should be checked after the fan has been in operation for 24 hours and before start-up when the unit has been disassembled.

Radial Gap: Adjust inlet cone position such that the radial gap between the wheel cone and inlet cone is evenly distributed around the wheel.

Radial gap is adjusted by loosening the inlet cone/ring bolts and centering the cone/ring on the wheel. If additional adjustment is required to maintain a constant radial gap, loosening the bearing bolts and centering the wheel is acceptable as a secondary option.

Overlap: Overlap is adjusted by loosening the wheel hub from the shaft and moving the wheel to the desired position along the shaft.

The transition between the inlet cone and wheel should be as shown; there is a smooth feel to the profile when moving from one component to the other.

Method for Centering Wheel: On belt drive units, centering can be accomplished by (a) loosening the inlet cone bolts to move the inlet cone or by (b) loosening the bearings in order to move the shaft. Wheel and inlet cone overlap can be adjusted by loosening the wheel hub set screws and moving the wheel to the desired position. Tighten all fasteners and set screws securely and realign drive pulleys after adjustment.

Wheel Rotation

Rotation direction of the wheel is critical. Incorrect rotation will result in reduced air performance, increased motor loading and possible motor burnout.

Check wheel rotation by momentarily energizing the unit and noting if rotation is in the same direction as the airflow at the outlet and conforms to the rotation decal affixed to the unit.

Wheels as viewed from the drive side:

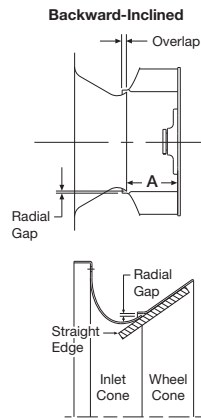
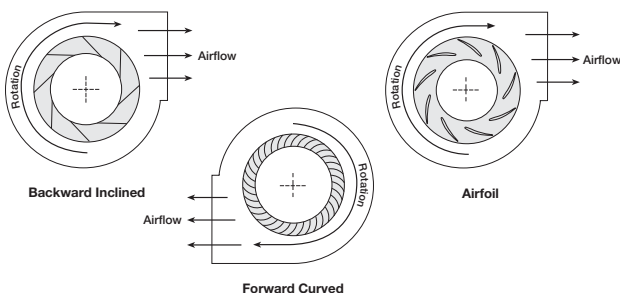

Radial Gap and Overlap Dimensions			
XUEFD-100-BI	A	Overlap	Overlap Tolerance
	inches (mm)		
110	5 ²³ / ₃₂ (145)	5/32 (4)	1/8 (3)
113	5 ²⁷ / ₃₂ (148)	7/32 (6)	1/8 (3)
115	6 ³¹ / ₃₂ (177)	5/32 (4)	1/8 (3)
116	7 1/2 (191)	1/8 (3)	1/8 (3)
118	9 (229)	3/16 (5)	1/8 (3)
XUEF-100-BI	A	Overlap	Overlap Tolerance
	inches (mm)		
104	4 3/4 (121)	1/8 (3)	1/16 (2)
106	4 3/4 (121)	1/8 (3)	1/16 (2)
108	4 3/4 (121)	1/8 (3)	1/16 (2)
110	4 3/4 (121)	1/8 (3)	1/16 (2)
113	5 3/4 (146)	1/4 (6)	1/8 (3)
115	6 1/2 (165)	1/2 (13)	3/16 (5)
116	7 1/8 (181)	1/2 (13)	3/16 (5)
118	8 9/16 (217)	5/8 (16)	1/4 (6)
120	7 9/16 (192)	5/8 (16)	1/4 (6)
124	10 13/16 (259)	3/4 (19)	3/8 (10)

Radial Gap and Overlap Dimensions					
XUEF-200	XUEF-300	XUEF-400	A	Overlap	Overlap Tolerance
			inches (mm)		
206	306		4 ¹⁵ / ₁₆ (125)	3/8 (10)	1/8 (3)
207	307		4 ¹⁵ / ₁₆ (125)	3/8 (10)	1/8 (3)
208	308		4 ¹⁵ / ₁₆ (125)	3/8 (10)	1/8 (3)
210	310		4 ¹⁵ / ₁₆ (125)	3/8 (10)	1/8 (3)
		407	1 ⁷ / ₁₆ (37)	2 ¹⁵ / ₃₂ (63)	1/8 (3)
		408	2 ¹¹ / ₁₆ (68)	1 ⁷ / ₃₂ (31)	1/8 (3)
		409	3 ¹¹ / ₁₆ (94)	7/32 (6)	1/8 (3)
		410	3 ¹¹ / ₁₆ (94)	7/32 (6)	1/8 (3)
212	312	412	4 1/4 (108)	1 ¹¹ / ₃₂ (9)	1/8 (3)
213	313	413	4 ¹¹ / ₁₆ (119)	3/8 (10)	1/8 (3)
215	315	415	5 ³ / ₁₆ (132)	7/16 (11)	1/8 (3)
216	316	416	5 3/4 (146)	7/16 (11)	1/8 (3)
218	318	418	6 ³ / ₈ (162)	1 ⁵ / ₃₂ (12)	1/8 (3)
220	320	420	7 (178)	1/2 (13)	3/16 (5)
222	322	422	7 ¹³ / ₁₆ (198)	1 ⁷ / ₃₂ (13)	3/16 (5)
	324	424	8 ⁵ / ₈ (219)	9/16 (14)	1/4 (6)
	327	427	9 ⁷ / ₁₆ (240)	1 ¹¹ / ₁₆ (17)	1/4 (6)
	330	430	10 ⁹ / ₁₆ (268)	1 ¹¹ / ₁₆ (17)	3/8 (10)
	333	433	11 ⁷ / ₁₆ (291)	1 ⁵ / ₁₆ (24)	3/8 (10)
	336	436	12 ³ / ₄ (324)	1 ⁵ / ₁₆ (24)	3/8 (10)
	340	440	14 ³ / ₁₆ (360)	2 ⁹ / ₃₂ (23)	3/8 (10)
	344	444	15 ⁹ / ₁₆ (395)	1 ¹ / ₈ (29)	3/8 (10)
	349	449	17 ¹ / ₈ (435)	1 ¹ / ₄ (32)	1/2 (13)

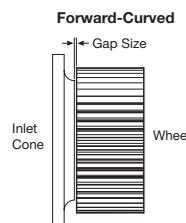

Gap Dimensions			
XUEFD-100-FC	Gap	XUEF-100-FC	Gap
106	3/8 (10)	109	1/4 (6)
107	3/8 (10)	110	1/4 (6)
109	1/2 (13)	112	1/4 (6)
110	1/2 (13)	115	1/4 (6)
		118	1/4 (6)
		120	1/4 (6)
		122	1/4 (6)
		124	1/4 (6)

Unit Start-Up

WARNING

Disconnect and secure to the **OFF** position all electrical power to the fan prior to inspection or servicing. Failure to comply with this safety precaution could result in serious injury or death.

DANGER

Pour écarter les risques de blessure grave ou de mort, débrancher et verrouiller l'alimentation électrique en position « Arrêt » avant tout contrôle ou entretien.

Visual Inspection of Equipment

The equipment type and arrangement should be verified as ordered at once when it arrives at the jobsite. When a discrepancy is found, the local representative must be notified immediately so that corrective action may be investigated. Verify electrical conformance to specifications. Unauthorized alterations and unauthorized backcharges will not be recognized by manufacturer.

After the unit has been assembled, installed and all utilities have been hooked up, the unit is now ready for operation.

Check

Before starting the unit, check the following:

1. Confirm that building supply voltage matches the voltage for which the unit is wired.
2. Check all piping and wiring penetrations made by contractors for water tightness. All penetrations must be made watertight to prevent water damage to the unit and building.
3. Rotate the fan wheel manually to be sure that it is free to operate. Remove any dirt or debris that may have accumulated during installation.
4. Check the fan bearing setscrews for tightness.
5. Check alignment of sheaves and V-belts. See Belt Drive Maintenance section.
6. Inspect all fasteners to ensure that none have loosened during shipment.
7. Check flex coupling for proper alignment and connect between motor shaft and fan shaft (direct drive).
8. Check all guarding to ensure that it is securely attached and not interfering with rotating parts.
9. Check all electrical connections for proper attachment.
10. Check housing and ductwork, if accessible, for obstructions and foreign material that may damage the fan wheel.
11. Fill drainage piping trap.

Additional Steps for Initial Start-Up

1. Check for proper wheel rotation by momentarily energizing the fan. Access to view the wheel can be gained through the blower housing access panel.



One of the most frequently encountered problems are motors that are wired to rotate the wheel in the wrong direction. This is especially true with 3-phase installations where the motor will run in either direction, depending on how it has been wired. To reverse rotation of a 3-phase motor, interchange any two of the three electrical leads. Single phase motors can be reversed by changing internal connections as described on the motor label or wiring diagram.

2. Fans with multi-speed motors should be checked on low speed during initial start-up.
3. Check for unusual noise, vibration or overheating of bearings. Refer to the “Troubleshooting” section of this manual if a problem develops.
4. Grease may be forced out of the bearing seals during initial start-up. This is a normal self-purging feature for the type of bearing used on this product.

NOTE

Model XUEF units should be operated only when attached to the system for which they were designed. Without proper system static pressure, the motor could be overloaded.

Model XUEFD-100-BI - Three-phase

This unit ships with the variable frequency drive (VFD) preprogrammed based on selected performance. No additional programming is required.

1. To operate, turn disconnect on and allow VFD to power up.
2. Once VFD display is shown, press *LO/RE* button which will switch control from remote to local.
3. If necessary, use vertical arrows to scroll through display screens to find frequency reference *F*.
4. Frequency should be programmed from factory. To balance system (by adjusting frequency), press *Enter* and use vertical arrows and *Reset / >* button until desired frequency is achieved. Press *Enter* to set frequency.
5. Press *Run* to start fan.
6. If additional adjustment is required, press *Stop* and repeat steps 3-4.

Vibration

On start-up and during operation, the unit should operate smoothly with minimal vibration. It is possible that a higher degree of vibration may be experienced. Excessive vibration if left unchecked, can cause a multitude of problems, including structural and/or component failure. The most common sources of vibration are listed.

Many of these conditions can be discovered by careful observation. Refer to the troubleshooting section of this manual for corrective actions. If observation cannot locate

Common Sources of Vibration

1. Wheel unbalance
2. Drive pulley misalignment
3. Incorrect belt tension
4. Bearing misalignment
5. Mechanical looseness
6. Faulty belts
7. Drive component unbalance
8. Poor inlet/outlet conditions
9. Foundation stiffness

the source of vibration, a qualified technician using vibration analysis equipment should be consulted. If the problem is wheel unbalance, in-place balancing can be done through the access panel located on the side of each fan's tubular housing. Any correction weights added to the wheel should be welded to either the wheel back (single-plane balance) or to the wheel back and wheel cone (two-plane balance).

Routine Maintenance and Operation

WARNING

Before taking any corrective action, make certain unit is not capable of operation during repairs.

AVERTISSEMENT

Avant d'entreprendre toute action corrective, s'assurer que l'appareil ne pourra pas fonctionner durant les réparations.

Once the unit has been put into operation, a routine maintenance schedule should be set up to accomplish the following:

1. Lubrication of bearings and motor.
2. Wheel, housing, bolts and set screws on the entire fan should be checked for tightness.
3. Any dirt accumulation on the wheel or in the housing should be removed to prevent unbalance and possible damage.
4. Inspect fan impeller and housing looking for fatigue, corrosion, or wear.

Fan Operation

All fans should be run every thirty (30) days, or at least "bumped" every thirty days. It is preferred that each fan is run as this causes all electrical and mechanical components to get up to temperature, displacing any formed condensation, redistributes load on bearings, and redistributes grease in the bearings (motor and shaft bearings).

IMPORTANT

When operating conditions of the fan are to be changed (speed, pressure, temperature, etc.), consult manufacturer to determine if the unit can operate safely at the new condition.

Motors

Motor maintenance is generally limited to cleaning and lubrication. Cleaning should be limited to exterior surfaces only. Removing dust and grease buildup on the motor housing assists proper motor cooling. Never wash down motor with high pressure spray.

Greasing of motors is only intended when fittings are provided. Many fractional motors are permanently lubricated for life and require no further lubrication. Motors supplied with grease fittings should be greased in accordance with the manufacturer's recommendations. When motor temperature does not exceed 104°F (40°C), the grease should be replaced after 2000 hours of running time.

Direct drive systems have extended grease lines to lubricate the motor without removal of any guarding.

Belt Drive Maintenance

V-belt drives must be checked on a regular basis for wear, tension, alignment and dirt accumulation. Premature or frequent belt failures can be caused by improper belt tension (either too loose or too tight) or misaligned sheaves. Abnormally high belt tension or drive misalignment will cause excessive bearing loads and may result in failure of the fan and/or motor bearings. Conversely, loose belts will cause squealing on start-up, excessive belt flutter, slippage and overheated sheaves. Either excessively loose or tight belts may cause fan vibration.

When replacing V-belts on multiple groove drives, all belts should be changed to provide uniform drive loading. Use a set of matched belts whenever possible. Do not pry belts on or off the sheave. Loosen belt tension until belts can be removed by simply lifting the belts off the sheaves. After replacing belts, ensure that slack in each belt is on the same side of the drive. Belt dressing should never be used.

Do not install new belts on worn sheaves. If the sheaves have grooves worn in them, they must be replaced before new belts are installed.

The proper tension for operating a V-belt drive is the lowest tension at which the belts will not slip at peak load conditions. Belts are adjusted by raising or lowering the motor pivot plate. For initial tensioning, the proper belt deflection halfway between sheave centers is $1/64$ -inch for each inch of belt span.

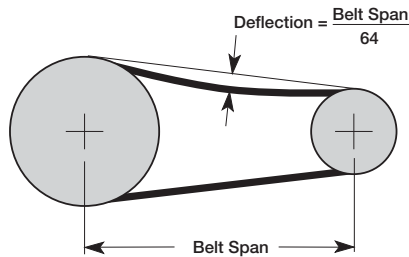

Check belt tension two times during the first 24 hours of operation and periodically thereafter.

XUEF-100 Belt Adjustment

Belts on the XUEF-100 are adjusted from the exterior of the fan. The end cover must be removed so that the belt(s) can be inspected and checked for proper tension.

1. Loosen, but DO NOT remove the four corner bolts on the adjustment plate.
2. Loosen, then adjust L-bolts on adjustment plate to tighten or loosen belt(s) as needed.
3. Tighten L-adjustment bolts and the four corner bolts to lock motor in place after proper tension is reached.

NOTE

Loosen the corner bolts as minimal as possible to allow the plate to move, but so the plate has minimal movement when bolts are re-tightened.

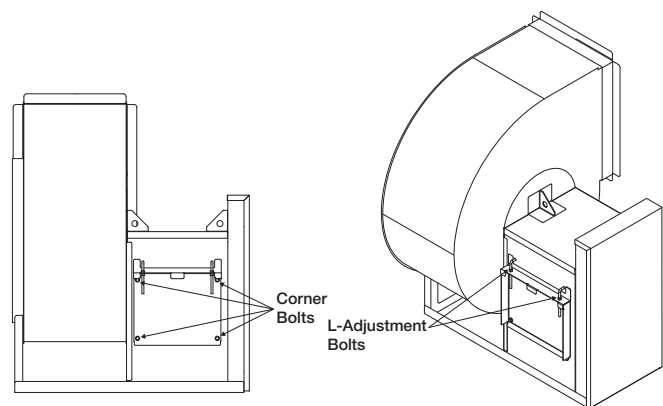

Wheel and Fastener Maintenance

Wheels require very little attention when exhausting clean air, however, air heavily laden with grease or dirt will tend to accumulate on the wheel causing unbalance. Wheels exhausting dirty or grease-laden air require frequent cleaning to assure smooth and safe operation.

All fasteners, including set screws in the bearing collars, should be checked for tightness each time maintenance checks are performed.

A proper maintenance program will help preserve the performance and reliability designed into the fan.

Bearing Lubrication Schedule

Shaft bearings are the most critical moving part of a fan. Therefore, special attention should be given to keeping the bearings clean and well lubricated. Proper lubrication provides for reduction in friction and wear, transmission and dissipation of heat, extended bearing life, and prevention of rust.

In order for a lubricant to fulfill these tasks, the proper grease applied at regular intervals is required. See the recommended bearing lubrication schedule below.

If unusual conditions exist (temperatures below 32°F or above 200°F), moisture or contaminants - more frequent lubrication is required.

Recommended Bearing Lubrication Schedule Relubrication Schedule in Months					
Standard Grease					
Fan RPM	Bearing Bore (inches)				
	1/2 - 1	1 1/8 - 1 1/2	1 5/8 - 1 7/8	1 15/16 - 2 3/16	2 7/16 - 3
To 250	12	12	12	12	12
500	12	12	11	10	8
750	12	9	8	7	6
1000	12	7	6	5	4
1250	12	6	5	4	3
1500	12	5	4	3	2
2000	12	3	3	2	1
2500	12	2	2	1	0.5
3000	12	2	1	0.5	0.25
3500	12	1	0.5	0.25	x
4000	12	0.5	0.25	x	x
5000	12	0.25	x	x	x
Number of Shots	4	8	8	10	16

- Lubrication interval is based on 12 hour per day operation and maximum 160°F housing temperature. For 24 hour per day operation, the interval should be cut in half.
- Lubricant should be added with the shaft rotating and until clean grease is seen purging from the bearing. The lubrication interval may be modified based on the condition of the purged grease. If bearing is not visible to observe purged grease, lubricate with number of shots indicated in chart for bore size.
- For conditions including high temperatures, moisture, dirt or excessive vibration, consult the factory for a specific lubrication interval for your application.
- Lubricant should be a high quality lithium complex grease conforming to NLGI Grade 2. Factory recommends Mobilux EP-2.
- The use of synthetic lubricants will increase lubrication intervals by approximately 3 times.

In addition to lubricating the bearings at specified intervals, set screws in the bearing collars should be checked for tightness. A bearing collar which has loosened will cause premature failure of the fan shaft. Fasteners attaching the bearings to the drive frame should also be checked.

Variable Frequency Drive Operation

For operation with a variable frequency drive (VFD), always check motor amps when adjusting the operating frequency. Motor may be sized for the original selected operating speed under 60 Hz. Bypassing the VFD or increasing the speed from this original selection, even if less than 60 Hz, may cause motor to overload or fail. Consult factory with fan serial number before increasing the upper limiting frequency.

Always check the fan rpm when adjusting the operating frequency. Do not exceed maximum class fan rpm of the wheel.

NOTE

It is the responsibility of the installing body to perform coast-down tests and identify any resonant frequencies after the equipment is fully installed. These resonant frequencies are to be removed from the operating range of the fan by using the "skip frequency" function in the VFD programming. Failure to remove resonant frequencies from the operating range will decrease the operating life of the fan and void the warranty.

Model XUEFD-100-BI – Variable Speed Drives

The XUEFD-100-BI comes equipped with a factory integrated speed controller. Single-phase models will use a electronically commutated (EC) motor with a potentiometer dial to adjust motor rpm. To change the speed, simply turn the dial. Three-phase models will offer a mounted, wired and programmed VFD and premium induction motor. Changing speeds on a 3-phase model involves pressing the up and down arrows located on the VFD interface.

Both single- and 3-phase versions feature a built-in electrical disconnect and the option for external control through 0-10 VDC signal.

Bearing Replacement

For Arrangement 10

The intent of this procedure is to allow a field service technician to replace bearings with the fan remaining in place in its intended application. All work can be conducted by accessing the bearings by either removing a shaft guard, a weatherhood or working under a weatherhood. This is dependent on the size of the unit. This procedure assumes the power source has been locked out prior to removing guards and covers, belts and pulleys have been loosened and removed properly, and extended lubrication lines have been disconnected at the bearing. In some cases, it may be necessary to remove the fan inlet cone and wheel if the bearings cannot be removed due to corrosion or damage. See Radial Gap, Overlap and Wheel Alignment on page 10 to the realign wheel upon installation.

Bearing Removal

This procedure assumes proper safety measures have been taken.

- Read and follow all instructions carefully.
 - Disconnect and lockout power before installation and maintenance.
 - Driven sheaves and belts have already been removed.
 - Shaft black coating can be removed with a solvent similar to a brake/carburetor cleaner.
1. Scribe a line around the shaft by both bearings and around the bearing base to the bearing support or write down the measurement from the end of the shaft to the bearings. This will help in repositioning the new bearing and wheel cone overlap.
 2. Follow the bearing manufacturers' procedures for removal and installation.
 3. Before removing the bearing bolts, make sure the shaft is supported slightly. Remember to consider the wheel weight on the shaft.
 4. Remove both bearings from the shaft and clean/remove any burrs using an emery cloth or file.
 5. Clean mounting surface of any dirt or grease.

Bearing Installation

1. Before installing, read bearing manufacturers' procedures. Before putting the new bearings on the shaft, you may need to break what is called swivel torque on the bearings (depending on style of bearing). This is done by holding the bearing housing securely and being able to move the inner bearing race around freely.
2. Apply light film of oil on shaft, then gently slide the new bearings onto the shaft.



Do not hammer bearing onto shaft!

3. Align bearings on shaft with the previous scribe marks that are on the shaft and lock bearing to shaft.
4. Put bolts into mounting surface and bearings. Do not tighten.
5. Remove blocks if shaft is supported.
6. Set bearings on support with the scribed marks locating the bearings. Make sure bearings are square and level with the shaft.
7. Tighten bolts and torque bearing bolts, bearing set screws/locking collars as per bearing manufacturers' procedures.
8. Rotate shaft by hand to help allow the bearings to help set in. At this time, listen for any unusual noises such as wheel rubbing on cone and any bearing noise.
9. Connect extended lube lines in new bearings if needed.
10. Reinstall the drive sheaves and belts. Check the belt alignment.
11. Make sure to reinstall all guards and follow proper safety measures before starting up the fan.

Parts List

Each fan bears a manufacturer's nameplate with model number and serial number embossed. This information will assist the local manufacturer's representative and the factory in providing service and replacement parts. Before taking any corrective action, make certain unit is not capable of operation during repairs.

CAUTION

A fan manufactured with an explosion resistant motor does not certify the entire unit to be explosion proof. Refer to UL Listing Mark for the fans approved usage.

CAUTION

La présence d'un moteur antidéflagrant sur un ventilateur ne garantit pas que tout l'appareil est antidéflagrant. Pour connaître les emplois autorisés de l'appareil, voir son marquage de conformité UL.

• XUEFD-100

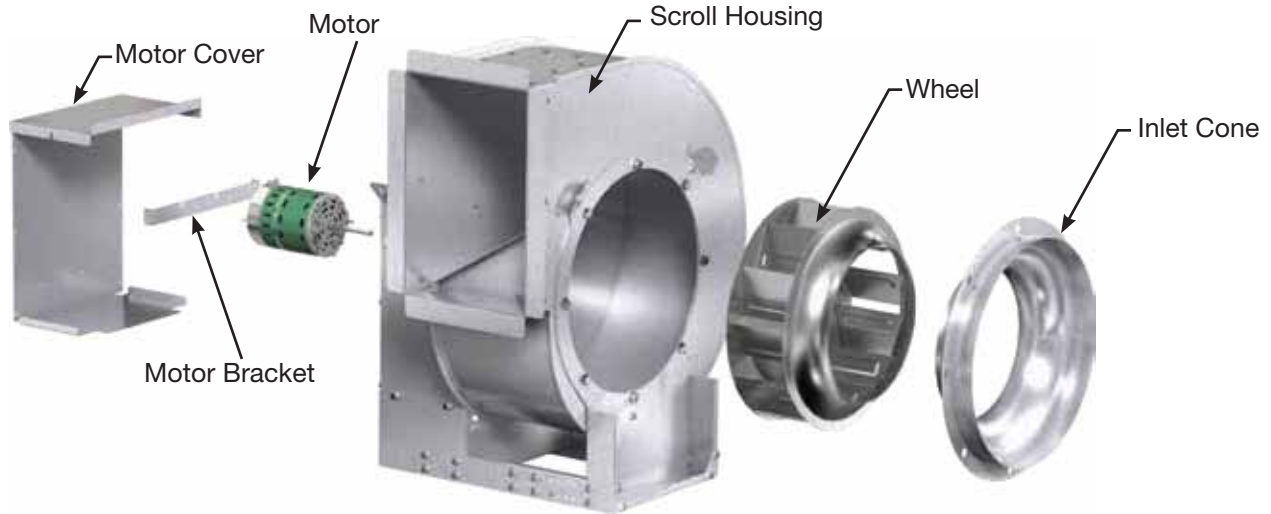

• XUEF-100

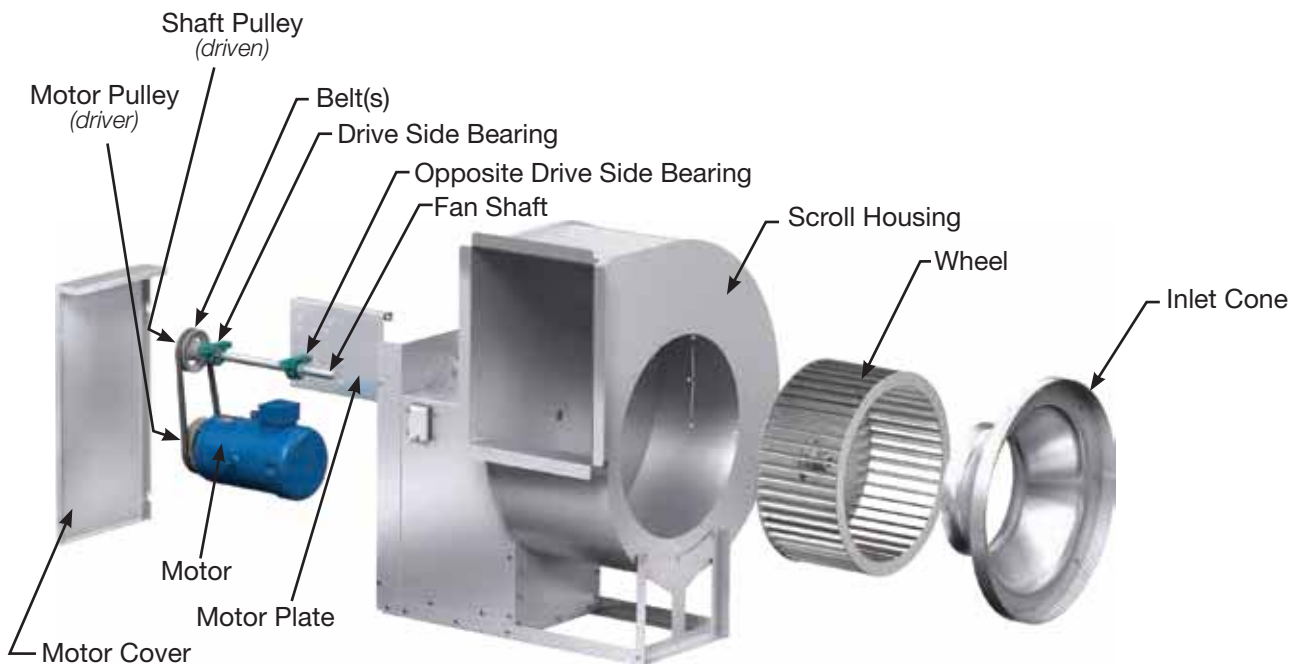

- XUEF-200
- XUEF-300

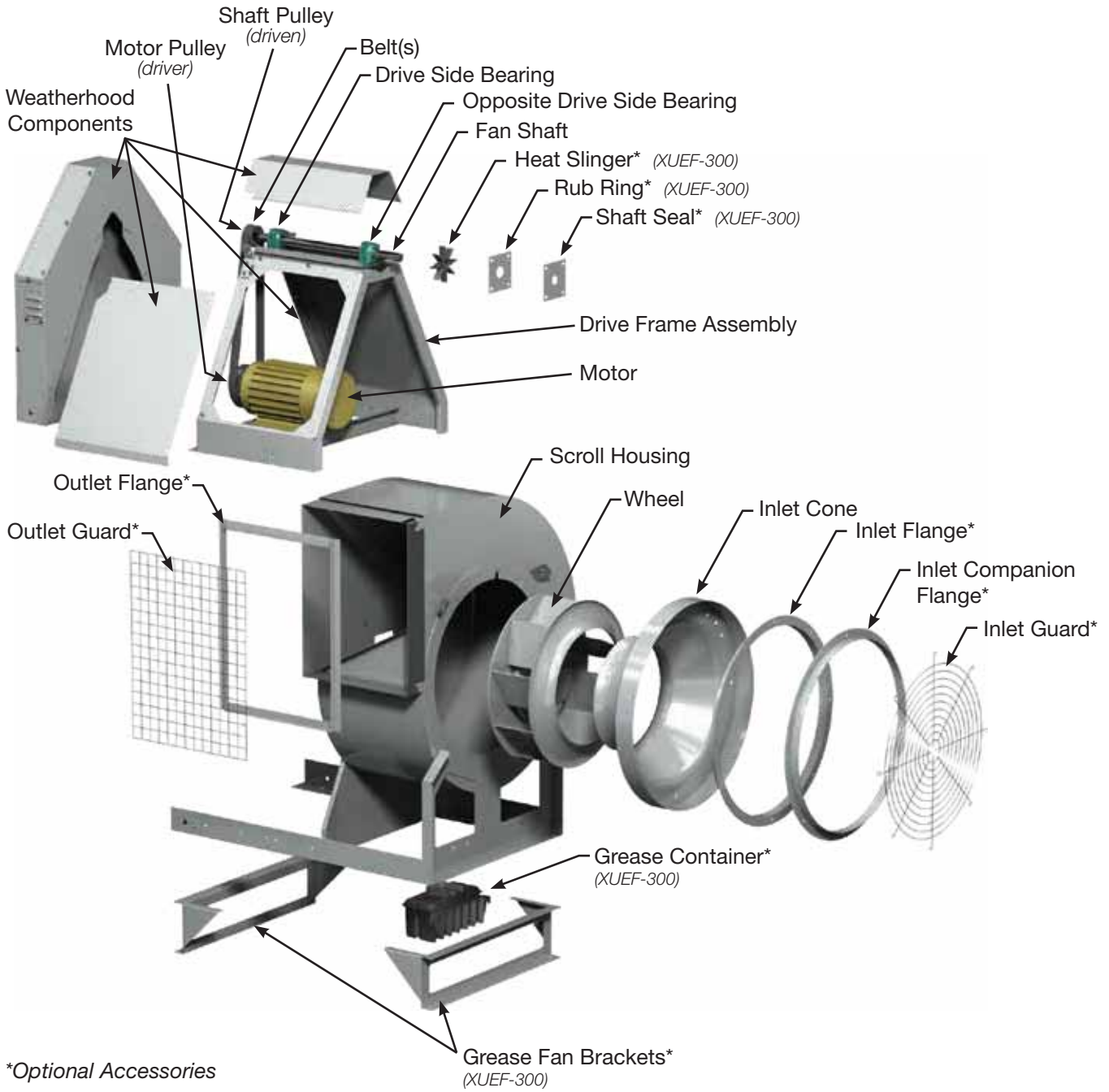

• XUEF-400

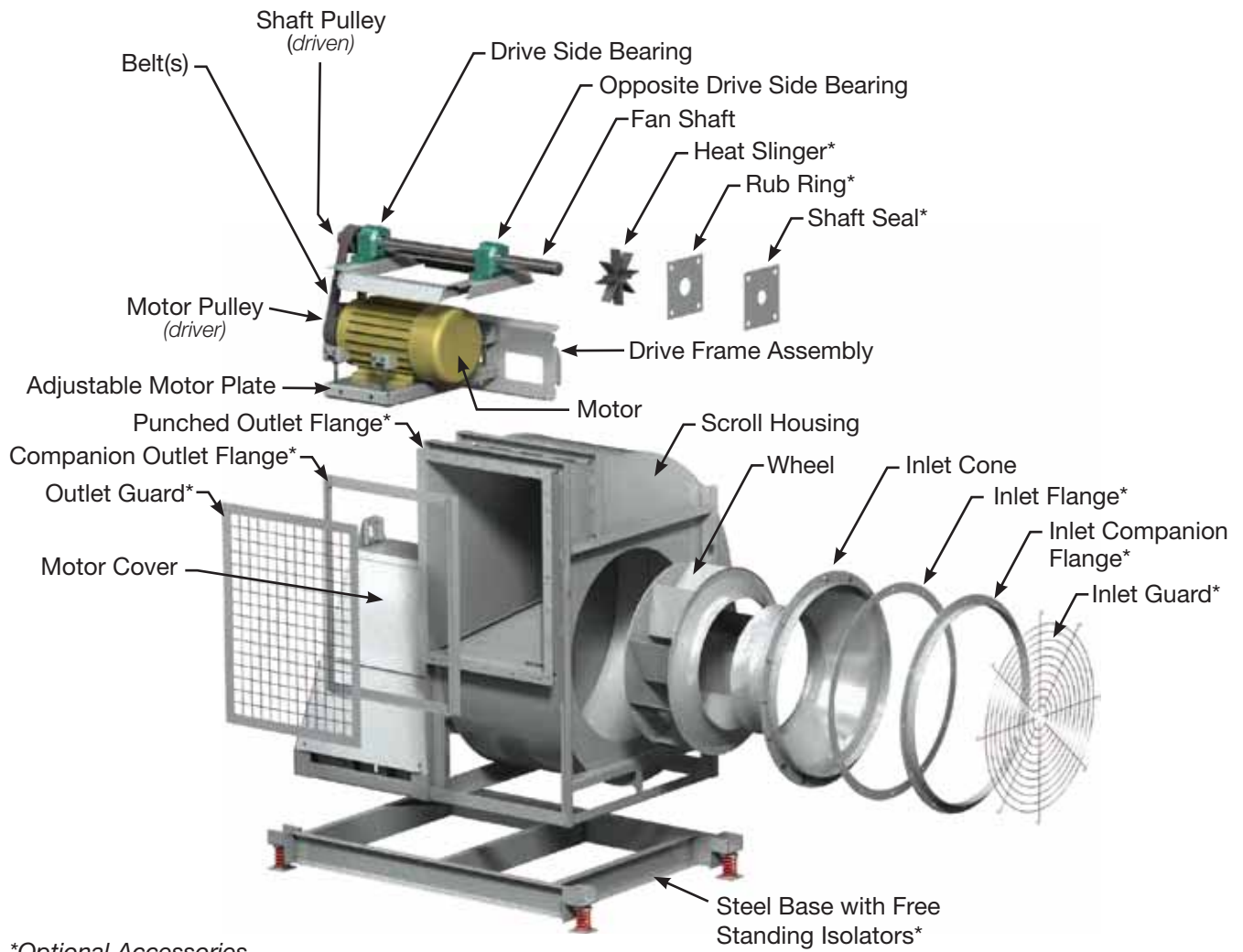

*Optional Accessories

Troubleshooting

WARNING

Before taking any corrective action, make certain unit is not capable of operation during repairs.

AVERTISSEMENT

Avant d'entreprendre toute action corrective, s'assurer que l'appareil ne pourra pas fonctionner durant les réparations.

Problem	Cause	Corrective Action
Excessive Noise	Wheel Rubbing Inlet	Adjust wheel and/or inlet cone. Tighten wheel hub or bearing collars on shaft.
	V-Belt Drive	Tighten sheaves on motor/fan shaft. Adjust belt tension. Align sheaves properly (see procedure). Replace worn belts or sheaves.
	Bearings	Replace defective bearing(s). Lubricate bearings. Tighten collars and fasteners.
	Wheel Unbalance	Clean all dirt off wheel. Check wheel balance.
Low CFM	Fan	Check wheel for correct rotation.
	Duct System	Higher pressure than design. Filters need replacement.
High CFM	Fan	Decrease fan speed.
	Duct System	Resize ductwork. Access door, filters, dampers not installed.
Static Pressure Wrong	Duct system has more or less restriction than anticipated	Remove obstructions in system. Use correction factor to adjust for temperature/altitude. Resize ductwork. Clean filters/coils. Change fan speed.*
High Motor Amp Draw	Fan	Check rotation of wheel. Reduce fan speed.
	Duct System	Resize ductwork. Check proper operation of isolation and bypass dampers. Check filters and access doors.
Fan Doesn't Operate	Electrical Supply	Check fuses/circuit breakers. Check for switches turned off or disconnected. Check for correct supply voltage.
	Drive	Check for broken belts. Tighten loose pulleys.
	Motor	Assure motor is correct horsepower and not tripping overload protector.
Overheated Bearing	Lubrication	Check for excessive or insufficient grease in the bearing.
	Mechanical	Replace damaged bearing. Relieve excessive belt tension. Align bearings. Check for bent shaft.
Excessive Vibration	Belts	Adjust tightness of belts. Replacement belts should be a matched set.
	System Unbalance	Check alignment of shaft, motor and pulleys. Adjustable pitch pulleys with motors over 15 hp are especially prone to unbalance. Check wheel balance, rebalance if necessary.

* Always check motor amps and compare to nameplate rating. Excessive fan speed may overload the motor and result in motor failure. Do not exceed the maximum cataloged rpm of the fan.

Maintenance Log

Date _____ Time _____ AM/PM
Notes: _____

Date _____ Time _____ AM/PM
Notes: _____

Date _____ Time _____ AM/PM
Notes: _____

Date _____ Time _____ AM/PM
Notes: _____

Date _____ Time _____ AM/PM
Notes: _____

Date _____ Time _____ AM/PM
Notes: _____

Date _____ Time _____ AM/PM
Notes: _____

Date _____ Time _____ AM/PM
Notes: _____

Date _____ Time _____ AM/PM
Notes: _____

Date _____ Time _____ AM/PM
Notes: _____



Larkin Industries, Inc.
114 David Green Rd., Birmingham, AL 35244
Phone: 1.800.322.4036 Fax: 1.205.987.0583
Email: Sales@larkinhoods.com