

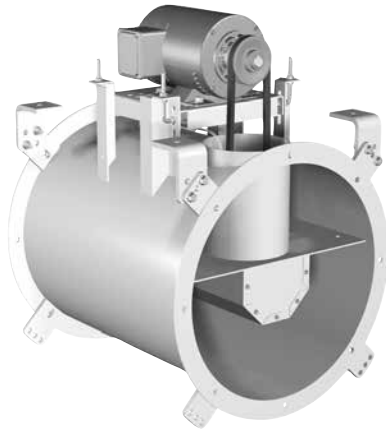

Installation, Operation and Maintenance Manual

Please read and save these instructions for future reference. Read carefully before attempting to assemble, install, operate or maintain the product described. Protect yourself and others by observing all safety information. Failure to comply with instructions could result in personal injury and/or property damage!



XTIF Inline
Level 1 & 2

General Safety Information

Only qualified personnel should install this fan. Personnel should have a clear understanding of these instructions and should be aware of general safety precautions. Improper installation can result in electric shock, possible injury due to coming in contact with moving parts, as well as other potential hazards. If more information is needed, contact a licensed professional engineer before moving forward.

1. Follow all local electrical and safety codes, as well as the National Electrical Code (NEC) and the National Fire Protection Agency (NFPA), where applicable. Follow the Canadian Electric Code (CEC) in Canada.
2. The rotation of the wheel is critical. It must be free to rotate without striking or rubbing any stationary objects.
3. Motor must be securely and adequately grounded.
4. Do not spin fan wheel faster than max cataloged fan RPM. Adjustments to fan speed significantly effects motor load. If the fan RPM is changed, the motor current should be checked to make sure it is not exceeding the motor nameplate amps.

5. Do not allow the power cable to kink or come in contact with oil, grease, hot surfaces or chemicals. Replace cord immediately if damaged.
6. Verify that the power source is compatible with the equipment.
7. Never open access doors to a duct while the fan is running.

DANGER

Always disconnect, lock and tag power source before installing or servicing. Failure to disconnect power source can result in fire, shock or serious injury.

CAUTION

When servicing the fan, motor may be hot enough to cause pain or injury. Allow motor to cool before servicing.

CAUTION

Precaution should be taken in explosive atmospheres.

Table of Contents

General Safety Information	1
Receiving	2
Unpacking	2
Handling	2
Storage	2-3
Inspection and Maintenance During Storage	3
Removing from Storage	3
General Information	
Unit and System Identification Tags	4
Pre-Installation Information	4
Electrical Disconnects	4
Moving Parts	4
Guards - Motor Cover, Shaft, Belt, Inlet or Outlet Guard	4
Access Doors	4
Air Pressure and Suction	4
Fans - Rigging and Lifting	5
Installation	
Effect of Installation on Performance	5
Typical Installations	5
Installation of UL/cUL 762 Listed Fans for Restaurant Exhaust	6-7
Drain Connection	7
Duct Connections	7
Sealant / Gasket / Seal Replacement	7
V-Belt Drives	
V-Belt Drive Installation	8
Alignment of Pulleys and Belts	8
Radial Gap, Overlap and Wheel Alignment	
Radial Gap and Alignment	8
Method for Centering Wheel	8
Radial Gap and Overlap Dimensions	9
Field Coating Touch-up	9
Unit Start-Up	
Visual Inspection of Equipment	10
Check	10
Additional Steps for Initial Start-Up	10
Electrical Connections	11
Vibration	11
Routine Maintenance and Operation	
Fan Operation	12
Motors	12
Belt Drive Maintenance	12
Bearing Lubrication Schedule	13
Wheel, Fasteners and Set Screws	13
Variable Frequency Drive Operation	13
Removal of Dust and Dirt	13
Cleaning Internal Components	13
Parts List	14
Troubleshooting	15
Maintenance Log	Backcover
Our Commitment	Backcover

Receiving

Upon receiving the product, check to ensure all items are accounted for by referencing the delivery receipt or packing list. Inspect each crate or carton for shipping damage before accepting delivery. Alert the carrier of any damage detected. The customer will make a notation of damage (or shortage of items) on the delivery receipt and all copies of the bill of lading which is countersigned by the delivering carrier. If damaged, immediately contact your Larkin Representative. Any physical damage to the unit after acceptance is not the responsibility of manufacturer.

Unpacking

Verify that all required parts and the correct quantity of each item have been received. If any items are missing, report shortages to your local representative to arrange for obtaining missing parts. Sometimes it is not possible that all items for the unit be shipped together due to availability of transportation and truck space. Confirmation of shipment(s) must be limited to only items on the bill of lading.

Handling

Fans are to be rigged and moved by the lifting brackets provided or by the skid when a forklift is used. Location of brackets varies by configuration and size. Handle in such a manner as to keep from scratching or chipping the coating. Damaged finish may reduce the ability of the fan to resist corrosion. Fans should never be lifted by the shaft, fan housing, motor, belt guard, or accessories.

Storage

- Rotate fan wheel monthly and purge bearings once every three months
- Energize fan motor once every three months
- Store belts flat to keep them from warping and stretching
- Store unit in a location which does not have vibration
- After storage period, purge grease before putting fan into service.

If storage of fan is in a humid, dusty or corrosive atmosphere, rotate the fan and purge the bearings once a month. Improper storage which results in damage to the fan will void the warranty.

Fans are protected against damage during shipment. If the unit cannot be installed and operated immediately, precautions need to be taken to prevent deterioration of the unit during storage. The user assumes responsibility of the fan and accessories while in storage. The manufacturer will not be responsible for damage during storage. These suggestions are provided solely as a convenience to the user.

INDOOR - The ideal environment for the storage of fans and accessories is indoors, above grade, in a low humidity atmosphere which is sealed to prevent the entry of blowing dust, rain or snow. Temperatures should be

evenly maintained between 30° to 110°F (-1° to 43°C), wide temperature swings may cause condensation and “sweating” of metal parts. All accessories must be stored indoors in a clean, dry atmosphere.

Remove any accumulations of dirt, water, ice, or snow and wipe dry before moving to indoor storage. To avoid “sweating” of metal parts allow cold parts to reach room temperature. To dry parts and packages use a portable electric heater to remove any moisture build up. Leave coverings loose to permit air circulation and to allow for periodic inspection.

The unit should be stored at least 3½ inches (89 mm) off the floor on wooden blocks covered with moisture proof paper or polyethylene sheathing. Aisles between parts and along all walls should be provided to permit air circulation and space for inspection.

OUTDOOR - Fans designed for outdoor applications may be stored outdoors, if absolutely necessary. Roads or aisles for portable cranes and hauling equipment are needed.

The fan should be placed on a level surface to prevent water from leaking into the fan. The fan should be elevated on an adequate number of wooden blocks so it is above water and snow levels and has enough blocking to prevent it from settling into soft ground. Locate parts far enough apart to permit air circulation, sunlight and space for periodic inspection. To minimize water accumulation, place all fan parts on blocking supports so rain water will run off.

Do not cover parts with plastic film or tarps as these cause condensation of moisture from the air passing through heating and cooling cycles.

Fan wheels should be blocked to prevent spinning caused by strong winds.

Inspection and Maintenance During Storage

While in storage, inspect fans once per month. Keep a record of inspection and maintenance performed.

If moisture or dirt accumulations are found on parts, the source should be located and eliminated. At each inspection, rotate the wheel by hand ten to fifteen revolutions to distribute lubricant in motor and bearings. If paint deterioration begins, consideration should be given to touch-up or repainting. Fans with special coatings may require special techniques for touch-up or repair.

Machined parts coated with rust preventive should be restored to good condition promptly if signs of rust occur. Immediately remove the original rust preventive coating with petroleum solvent and clean with lint-free cloths. Polish any remaining rust from surface with crocus cloth or fine emery paper and oil. Do not destroy the continuity of the surfaces. Thoroughly wipe clean with Tectyl® 506 (Ashland Inc.) or the equivalent. For hard to reach internal surfaces or for occasional use, consider using Tectyl® 511M Rust Preventive, WD-40® or the equivalent.

Removing from Storage

As fans are removed from storage to be installed in their final location, they should be protected and maintained in a similar fashion until the fan equipment goes into operation.

Prior to assembly and installation of the unit and system components, inspect the fan assembly to make sure it is in working order.

1. Check all fasteners, set screws on the fan, wheel, bearings, drive, motor base and accessories for tightness.
2. Rotate the fan wheel by hand and assure no parts are rubbing. Access to the wheel is obtained through a bolted panel located on the side of the fan housing
3. Ensure proper wheel settings for radial gap and alignment. Refer to Radial Gap, Overlap and Wheel Alignment section on page 8.

General Information

To ensure a successful installation, the instructions in this manual should be read and adhered to. Failure to comply with proper installation procedures may void the warranty.

Unit and System Identification Tags

Each fan has a permanently affixed manufacturer's engraved metal nameplate containing the model number and individual serial number.

The tag shown is an example of an identification nameplate on the fan. The information provides general details about the fan, as well as containing specific information unique to the unit.

When contacting your Larkin representative with future needs or

questions, please have the information on this label available. Tags are mounted in an area which is clearly visible, usually on the side of the fan housing.



Pre-Installation Information

Before installation, it is important to be certain the mounting surface will bear the operating weight of the unit. For proper unit operation, it is also important that it be operated in a completely level position.

For further details on safety practices involving industrial and commercial fans, please refer to AMCA Publication 410.

Electrical Disconnects

All fan motors should have disconnects located in close visual proximity to turn off electrical service. Service disconnects shall be locked-out when maintenance is being performed.

Moving Parts

All moving parts must have guards to protect personnel. Refer to local codes for requirements as to the number, type and design. Fully secure fan wheel before performing any maintenance. The fan wheel may start "free wheeling" even if all electrical power has been disconnected. Before the initial start-up or any restart, check the following items to make sure that they are installed and secure.

- Do not spin fan wheel faster than the maximum cataloged fan rpm.
- Adjustments to fan speed significantly effects motor load. If the fan RPM is changed, the motor current should be checked to make sure it is not exceeding the motor nameplate amps.

Guards – Motor Cover, Shaft, Belt, Inlet or Outlet Guard

Do not operate fans without proper protective devices in place. Failure to do so may result in serious bodily injury and property damage. Check local codes to ensure compliance for all protective devices.

Access Doors

Before opening access doors, ensure the fan wheel has stopped moving and that the wheel has been secured from being able to rotate. Do not operate fan without access door in its fully closed position.

Provisions to open and remove the access door is required for periodic cleaning and maintenance. The access door is clearly labeled and indicates that access to this location must be maintained. Any enclosure openings required to reach the access panel shall be large enough to allow for the removal of the panel.

Air Pressure and Suction

In addition to the usual hazards associated with rotating machinery, fans also create a dangerous suction at the inlet. Special caution needs to be used when moving around a fan, whether it is in operation or not. Before start-up, make sure the inlet area is clear of personnel and loose objects.

Fans - Rigging and Lifting

IMPORTANT

Fans should never be lifted by shaft, motor, motor cover or accessories.

Fans are to be rigged and moved by the lifting brackets provided or by the skid when a forklift is used. Location of brackets varies by model and size. XTIF Inline models have mounting brackets located at the ends of the fan housing with which slings can be attached (Fig. 1).

Handle in such a manner as to keep from scratching or chipping the coating. Damaged finish may reduce ability of fan to resist corrosion.

- Use standard lifting rigging practices.
- **ALL** lifting brackets on each component must be utilized at the same time.
- Fan to be kept level during lifting and installation.

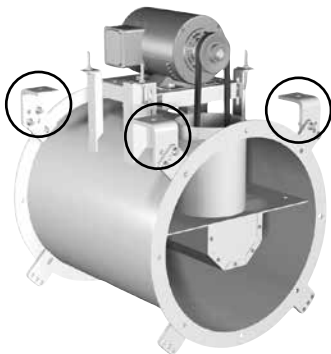

Fig. 1

Installation

Move the fan to the desired location. Check and tighten fasteners throughout the unit and then fasten securely through mounting holes provided in the base angles. The unit must be set level (shimming may be necessary). Flexible duct connections and vibration isolators should be used where noise is a factor.

The motor voltage and ampere rating must be checked for compatibility with the electrical supply prior to final electrical connection. Supply wiring to the fan must be properly fused and conform to local and national electrical codes.

Effect of Installation on Performance

Any installation with inlet or discharge configurations that deviate from these recommendations may result in reduced fan performance. Restricted or unstable flow at the fan inlet can cause pre-rotation of incoming air or even loading of the fan wheel yielding large system losses and increased sound levels. Free discharge or turbulent flow in the discharge ductwork will also result in system effect losses.

The most common inlet and discharge conditions which affect fan performance are:

INLET DUCT TURNS

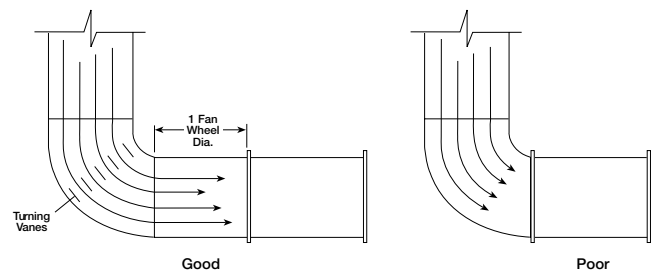

Installation of a duct turn or elbow too close to the fan inlet reduces fan performance because air is loaded unevenly into the fan wheel. To achieve full fan performance there should be at least one to two fan wheel diameters between the turn or elbow and the fan inlet.

DISCHARGE DUCT TURNS

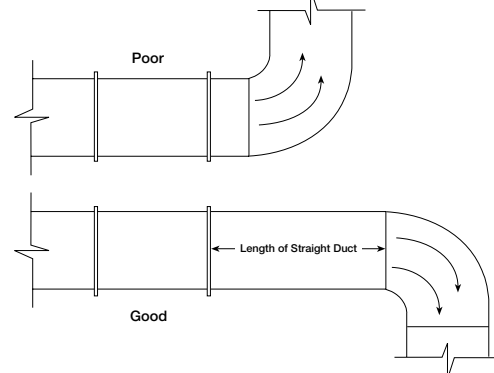

Fan performance is reduced when duct turns are made immediately off the fan discharge. To achieve cataloged fan performance, there should be at least one equivalent duct diameter of straight ductwork between the fan discharge and any duct turns.

Typical Installations

Following are typical mounting installations for model XTIF (horizontal or vertical). For horizontal XTIF's with motor in the 3 or 9 o'clock position or vertical installations, additional mounting rails are recommended. Mounting rail dimensions are shown for field fabrication.

Horizontal Ceiling Hung

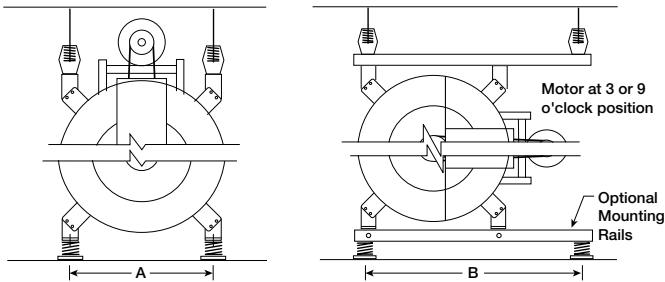

Horizontal Base Mount

Vertical Ceiling Hung

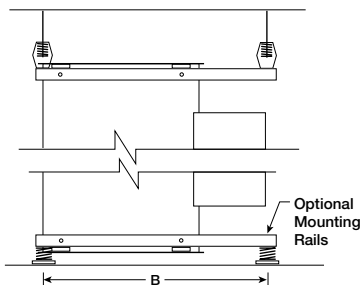

Vertical Base Mount with airflow up or down

Mounting Hole Locations – inches (millimeters)

Fan Size	A	B	Depth*
9	17½ (445)	26 (660)	18⅝ (467)
10	17½ (445)	26 (660)	18⅝ (467)
12	17½ (445)	26 (660)	18⅝ (467)
13	19 (483)	28½ (724)	19⅞ (505)
16	21¼ (552)	33 (838)	23⅞ (606)
18	26¼ (667)	37 (940)	26⅞ (670)
22	30½ (775)	44 (1118)	29⅞ (752)
24	35 (889)	50 (1270)	33⅞ (841)
30	42 (1067)	56 (1422)	42⅞ (1083)
36	46¾ (1187)	62 (1575)	48⅞ (1222)

*Depth dimension is the center distance between holes in the front and rear mounting brackets.

Installation of UL/cUL 762 Listed Fans for Restaurant Exhaust

This section is to provide additional information when dealing with fans used in applications involving grease-laden air.

All units used in applications with grease-laden air are to be installed in accordance to NFPA 96, IMC 2203 and local codes. Consult local code authorities for your specific requirements.



Fans shall be located in an easily accessible area of adequate size to allow for service or removal. Exhaust fans with ductwork connected to both ends shall have access for cleaning and inspection within 3 ft. (915 mm) of each end of the fan (NFPA 96).

Maintain a minimum clearance of at least 18 inches (457 mm) to combustible material and 6 inches (152 mm) to either limited-combustible or noncombustible material (NFPA 96).

Fans are to be installed with the motors in the 3 or 9 o'clock (C or G) positions. Motors located in this configuration may cause an unbalanced load that should be considered if isolators are to be used. Equalized loading between isolators can be achieved through the use of mounting rails.

It is recommended to install the fan near the end of the duct run. This limits the amount of positive pressure in the system. The diagram illustrates an inline fan exhausting air near the final termination point. See local codes and NFPA 96 for any restrictions and requirements for wall terminations.

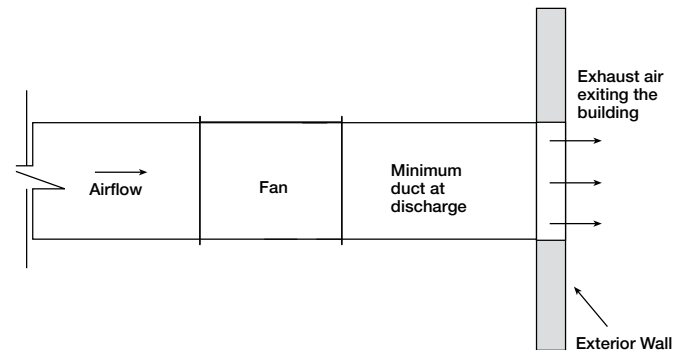

Drain Connection with UL/cUL 762

A drain is provided for single-point drainage of water and residue. Drains are located 90° from the motor location to allow for removal of grease and moisture. When installed correctly, one of the two housing drains will be located on the bottom. This drain is used to remove any accumulated grease and/or cleaning solutions. Some means for collection of this residue must be provided, either a container directly under the drain or use an adapter and pipe to carry the residue to a remote collection point. Remove drain plug prior to connection to grease collection device.

Positive Pressure Trap

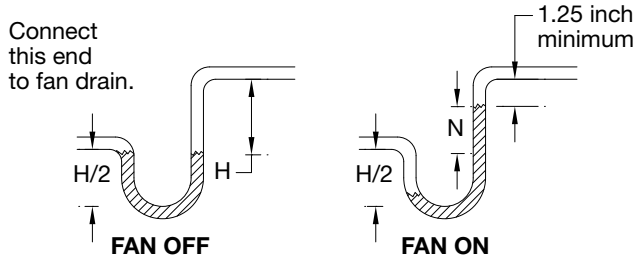

N = Negative fan pressure (inches W.C.)
H = N - 0.5 inches minimum

Duct Connections

Inline fans shall be connected to the exhaust duct by flanges securely bolted as shown in the figures below (NFPA 96). Flexible connectors shall not be used. Units supplied with matching companion flanges are to have this part welded to the ductwork and then bolted to the fan. Gaskets used in the over-lapping connection style shall not be positioned in a manner to have direct contact with the grease.

Sealant Connection

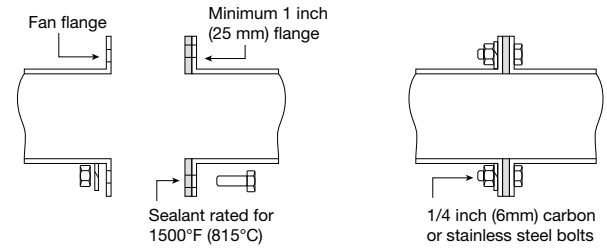

Over-Lapping Connection

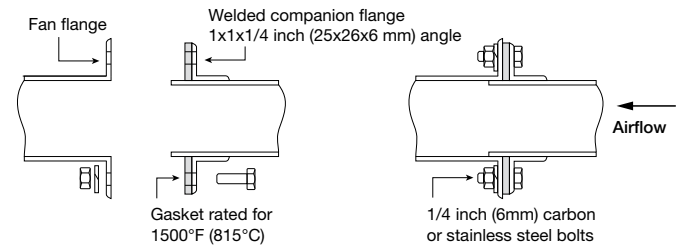

Sealant / Gasket / Seal Replacement

Repair or replace sealant / gasket as needed. Replacement sealant or gasket shall be rated for 1500°F (815°C) and shall be grease tight. See Sealant and Over-lapping Connection figures for proper installation.

Replace access door or bearing cover gasket material as needed. Gasket material for the access door is 1/2 x 1/2 inch (13 x 13 mm). Gasket for the bearing cover is 1/8 x 1/2 inch (4 x 13 mm).

A mechanical seal, located inside the bearing cover, is used to keep grease from penetrating into this area. Contact your Larkin Representative with the fan's serial number for appropriate sizing and part numbers for a replacement seal or gasket material.

V-Belt Drives

V-Belt Drive Installation

1. Remove the protective coating from the end of the fan shaft using mineral spirits or another similar solvent. Check to ensure that the shaft is free of nicks and burrs.
2. Slide sheaves on shafts. Do not drive sheaves on as this may result in bearing damage.
3. Align fan and motor sheaves with a straight edge or string and tighten.
4. Place belts over sheaves. Do not pry or force belts, as this could result in damage to the cords in the belts.
5. Adjust the tension until the belts appear snug. Run the unit for a few minutes and allow the belts to “set” properly.
6. With the fan off and disconnect locked out, adjust the belt tension by moving the motor pivot plate. When in operation, the tight side of the belts should be in a straight line from sheave to sheave with a slight bow on the slack side.

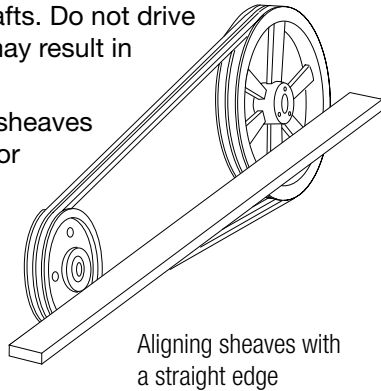

Alignment of Pulleys and Belts

Check pulleys and belts for proper alignment to avoid unnecessary belt wear, noise, vibration and power loss. Motor and drive shafts must be parallel and pulleys in line as shown in Figure 2.

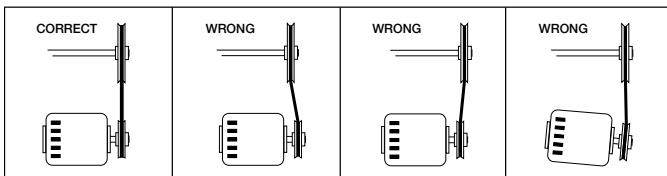

Figure 2

The adjustable motor pulley is set at the factory for the fan RPM specified by the customer. Fan RPM can be increased by closing or decreased by opening the adjustable motor pulley. Multigroove variable pitch pulleys must be adjusted an equal number of turns open or closed. Any increase in fan speed represents a substantial increase in load on the motor.

To avoid motor overheating and possible burnout, motor load amperes should always be checked and compared to nameplate rating when fan speed is increased.

Radial Gap, Overlap and Wheel Alignment

Wheels must rotate freely and not rub on the inlet cone. Model XTIF wheels overlap the inlet cone. Refer to the table on the next page for the proper dimension.

Radial Gap and Alignment

Efficient fan performance can be maintained by having the correct radial gap, overlap and wheel alignment. These items should be checked after the fan has been in operation for 24 hours and before start-up when the unit has been disassembled.

Radial Gap: Adjust inlet cone position such that the radial gap between the wheel cone and inlet cone is evenly distributed around the wheel.

Radial gap is adjusted by loosening the inlet cone/ring bolts and centering the cone/ring on the wheel. If additional adjustment is required to maintain a constant radial gap, loosening the bearing bolts and centering the wheel is acceptable as a secondary option.

Overlap: Overlap is adjusted by loosening the wheel hub from the shaft and moving the wheel to the desired position along the shaft.

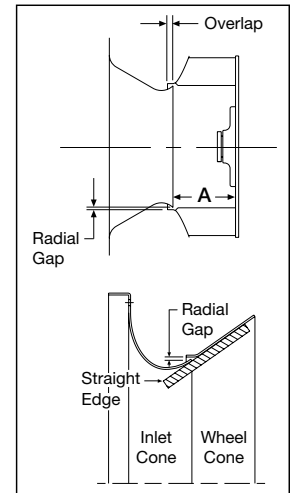

The transition between the inlet cone and wheel should be as shown; there is a smooth feel to the profile when moving from one component to the other.

Method for Centering Wheel: On belt drive units, centering can be accomplished by (a) loosening the inlet cone bolts to move the inlet cone or by (b) loosening the bearings in order to move the shaft. Wheel and inlet cone overlap can be adjusted by loosening the wheel hub set screws and moving the wheel to the desired position. Tighten all fasteners and set screws securely and realign drive pulleys after adjustment.

Radial Gap and Overlap Dimensions

Fan Size	Level	Overlap	A
		inches (millimeters)	
09	1	¼ (6)	
	2	½ (13)	3¾ (81)
10	1	¼ (6)	
	2	¼ (6)	3¾ (87)
12	1	¼ (6)	
	2	⅜ (10)	4 (102)
13	1	¼ (6)	
	2	7/16 (11)	47/16 (113)
16	1	¼ (6)	
	2	7/16 (11)	57/16 (138)
18	1	⅜ (10)	
	2	½ (13)	6¾ (162)
22	1	⅜ (10)	
	2	9/16 (14)	713/16 (198)
24	1	⅜ (10)	
	2	11/16 (17)	97/16 (240)
30	1	½ (13)	
	2	11/16 (17)	109/16 (268)
36	1	½ (13)	
	2	15/16 (24)	12¾ (324)

Field Coating Touch-Up for Scratched Areas

Standard coating and color is Larkin's RAL 7023 Concrete Grey. Failure to perform touch-ups may result in rust or corrosion and accelerate the fade in color and is not covered under warranty.

TOUCH-UP PAINT REPAIR KIT CONTENTS

- One Zinc Clad Aerosol Can
- One pint (recoat epoxy primer grey) with one pint (recoat epoxy primer catalyst)
- One quart H.S. Polyurethane
- One Scotch-Brite scratch pad
- Two 1-1/2 inch wide paint brushes
- Four pint-sized empty cans for mixing
- One quart-sized empty can for mixing
- Zinc repair instructions
- MSDS sheets

To order a coating repair kit, please reference Larkin's part number HAZ2597 PNT FIELD REPAIR KIT, RAL 7023 CONCRETE GREY. Please contact factory with your fan's serial number for colors other than our standard.

Unit Start-Up

Visual Inspection of Equipment

The equipment type and arrangement should be verified as ordered at once when it arrives at the jobsite. If a discrepancy is found, the local Larkin Sales Representative must be notified immediately so that corrective action may be investigated. Also verify electrical conformance to specifications. Unauthorized alterations and unauthorized backcharges will not be recognized by Accurex, LLC.

After the unit has been assembled, installed and all utilities have been hooked up, the unit is now ready for operation.

Check

Before starting the unit, check the following:

1. Confirm that building supply voltage matches the voltage for which the unit is wired.
2. Check all piping and wiring penetrations made by contractors for water tightness. All penetrations must be made watertight to prevent water damage to the unit and building.
3. Rotate the fan wheel manually to be sure that it is free to operate. Remove any dirt or debris that may have accumulated during installation.
4. Check the fan bearing setscrews for tightness.
5. Check alignment of sheaves and V-belts.
6. Inspect all fasteners to ensure that none have loosened during shipment.
7. Check all guarding to ensure that it is securely attached and not interfering with rotating parts.
8. Check all electrical connections for proper attachment.
9. Check housing and ductwork, if accessible, for obstructions and foreign material that may damage the fan wheel.
10. Fill drainage piping trap.

Additional Steps for Initial Start-Up

1. Check for proper wheel rotation by momentarily energizing the fan. The wheel rotation should be in the same direction as the rotation decal affixed to the unit.

One of the most frequently encountered problems are motors that are wired to rotate the wheel in the wrong direction. This is especially true with 3-phase installations where the motor will run in either direction, depending on how it has been wired. To reverse rotation of a 3-phase motor, interchange any two of the three electrical leads. Single phase motors can be reversed by changing internal connections as described on the motor label or wiring diagram.

2. Fans with multi-speed motors should be checked on low speed during initial start-up.
3. Check for unusual noise, vibration or overheating of bearings. Refer to the "Troubleshooting" section of this manual if a problem develops.
4. Grease may be forced out of the bearing seals during initial start-up. This is a normal self-purging feature for the type of bearing used on this product.

Electrical Connections

Before electrical connections are made, the supply voltage, phase and ampere capacity must be checked for compatibility with the fan motor. In addition, the supply wiring must be properly fused and conform to local and national electrical codes. If the unit is supplied with a safety disconnect switch, ensure proper wiring to the fan motor. Be sure the disconnect is switched to the "OFF" position before connecting supply wires. If no disconnect is supplied, ensure the supply wire is not live before connection. Supply wires are then connected to the optional safety disconnect switch (if supplied) or wired directly to the motor.

Vibration

On start-up and during operation, the unit should operate smoothly with minimal vibration. It is possible that a higher degree of vibration may be experienced. Excessive vibration, if left unchecked, can cause a multitude of problems, including structural and/or component failure. The most common sources of vibration are listed.

Common Sources of Vibration

1. Wheel Unbalance
2. Drive Pulley Misalignment
3. Incorrect Belt Tension
4. Bearing Misalignment
5. Mechanical Looseness
6. Faulty Belts
7. Drive Component Unbalance
8. Poor Inlet/Outlet Conditions
9. Foundation Stiffness

Many of these conditions can be discovered by careful observation. Refer to the troubleshooting section of this manual for corrective actions. If observation cannot locate the source of vibration, a qualified technician using

vibration analysis equipment should be consulted. If the problem is wheel unbalance, in-place balancing can be done through the access panel located on the side of each fan's tubular housing. Any correction weights added to the wheel should be welded to either the wheel back (single-plane balance) or to the wheel back and wheel cone (two-plane balance).

Routine Maintenance and Operation

WARNING

Disconnect and secure to the “OFF” position all electrical power to the fan and secure fan wheel prior to inspection or servicing. Failure to comply with this safety precaution could result in serious injury or death.

Once the unit has been put into operation, a routine maintenance schedule should be set up to preserve the reliability and performance of the fan and accomplish the following:

1. Lubrication of bearings and motor.
2. Wheel, housing, bolts and set screws on the entire fan should be checked for tightness.
3. Any dirt accumulation on the wheel or in the housing should be removed to prevent unbalance and possible damage.
4. Inspect fan impeller and housing looking for fatigue, corrosion, or wear.

Fan Operation

All fans should be run every thirty (30) days, or at least “bumped” every thirty days. It is preferred that each fan is run as this causes all electrical and mechanical components to get up to temperature, displacing any formed condensation, redistributes load on bearings, and redistributes grease in the bearings (motor and shaft).

CAUTION

When operating conditions of the fan are to be changed (speed, pressure, temperature, etc.), consult manufacturer to determine if the unit can operate safely at the new condition.

Motors

Motor maintenance is generally limited to cleaning and lubrication. Cleaning should be limited to exterior surfaces only. Removing dust and grease buildup on the motor housing assists proper motor cooling. Never wash-down motor with high pressure spray.

Greasing of motors is only intended when fittings are provided. Many fractional motors are permanently lubricated for life and require no further lubrication. Motors supplied with grease fittings should be greased in accordance with the manufacturer’s recommendations. When motor temperature does not exceed 104°F (40°C), the grease should be replaced after 2000 hours of running time.

Belt Drive Maintenance

V-belt drives must be checked on a regular basis for wear, tension, alignment and dirt accumulation. Premature or frequent belt failures can be caused by improper belt tension (either too loose or too tight) or misaligned sheaves. Abnormally high belt tension or drive misalignment will cause excessive bearing loads and may result in failure of the fan and/or motor bearings. Conversely, loose belts will cause squealing on start-up, excessive belt flutter, slippage and overheated sheaves. Either excessively loose or tight belts may cause fan vibration.

When replacing V-belts on multiple groove drives all belts should be changed to provide uniform drive loading. Use a set of matched belts whenever possible. Do not pry belts on or off the sheave. Loosen belt tension until belts can be removed by simply lifting the belts off the sheaves. After replacing belts, ensure that slack in each belt is on the same side of the drive. Belt dressing should never be used.

Do not install new belts on worn sheaves. If the sheaves have grooves worn in them, they must be replaced before new belts are installed.

The proper tension for operating a V-belt drive is the lowest tension at which the belts will not slip at peak load conditions. Belts are adjusted by raising or lowering the motor pivot plate. Use the bolts in the slotted brackets and adjustment rods with bolts as adjustment points until proper belt tension is attained.

For initial tensioning, the proper belt deflection halfway between sheave centers is 1/64-inch for each inch of belt span.

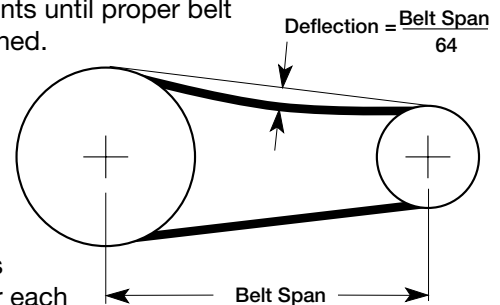

Check belt tension two times during the first 24 hours of operation and periodically thereafter.

Bearing Lubrication Schedule

Shaft bearings are the most critical moving part of a fan. Therefore, special attention should be given to keeping the bearings clean and well lubricated. Proper lubrication provides for reduction in friction and wear, transmission and dissipation of heat, extended bearing life and prevention of rust.

In order for a lubricant to fulfill these tasks, the proper grease applied at regular intervals is required. See bearing manufacturer's instructions or label on the fan house for lubrication schedule.

In a clean environment and temperature above 32°F (0°C) and below 200°F (93°C), fan shaft bearings with grease fittings should be lubricated semi-annually using a high quality lithium based grease. If unusual conditions exist (temperatures below 32°F or above 200°F), moisture or contaminants - more frequent lubrication is required. **Lubricate bearings on UL762 fans with high temperature grease conforming to NLGI Grade 2, such as Mobil Mobilith SHC 100 or 200.**

With the unit running, add grease very slowly with a manual grease gun until a slight bead of grease forms at the seal. Be careful not to unseat the seal by over lubricating or using excessive pressure. Bearings without grease fittings are lubricated for life.

Fasteners attaching the bearings to the drive frame should also be checked.

Wheel, Fasteners and Set Screws

Wheels require very little attention when exhausting clean air, however, air heavily laden with grease or dirt will tend to accumulate on the wheel causing unbalance. Wheels exhausting dirty or grease-laden air require frequent cleaning to assure smooth and safe operation.

All fasteners, including set screws in the bearing collars, should be checked for tightness each time maintenance checks are performed. Particular attention should be paid to set screws attaching the wheel to the shaft and the shaft to the bearings. Loose bearing set screws will lead to premature failure of the fan shaft.

A proper maintenance program will help preserve the performance and reliability designed into the fan.

Variable Frequency Drive Operation

For operation with variable frequency drive (VFD), always check motor amps when adjusting the operating frequency. Motor may be sized for the original selected operating speed under 60 Hz. Bypassing the VFD or increasing the speed from this original selection, even if less than 60 Hz, may cause motor to overload or failure. Consult factory with fan serial number, before increasing the upper limiting frequency.

Always check the fan rpm when adjusting the operating frequency. Do not exceed maximum class fan rpm of the wheel.

Removal of Dust and Dirt

Dirt clogs cooling vents on the motor housing, contaminates bearing lubricant, and collects on the impeller causing severe imbalance if left unchecked. The exterior surface of the motor and impeller should be thoroughly cleaned periodically. Use caution and do not allow water or solvents to enter the motor or bearings. Under no circumstances should motors or bearings be sprayed with steam or water.

Cleaning Internal Components

Entire wheel should be cleaned during routine duct cleaning. Partial cleaning may result in an unbalanced wheel that can cause premature bearing failure or excessive vibration.

Grease / cleaning solution should drain freely through the provided drain connection. Remove any obstructions inhibiting proper drainage.

Only the access door is removed during routine duct cleaning. The bearing cover is not removed during routine cleaning. The bearing cover is removed only when inspecting or changing the bearings, fan shaft or driven pulley.

Parts List

Each fan bears a manufacturer's nameplate with model number and serial number embossed. This information, in addition to the parts list shown, will assist the local Larkin representative and the factory in providing service and replacement parts.

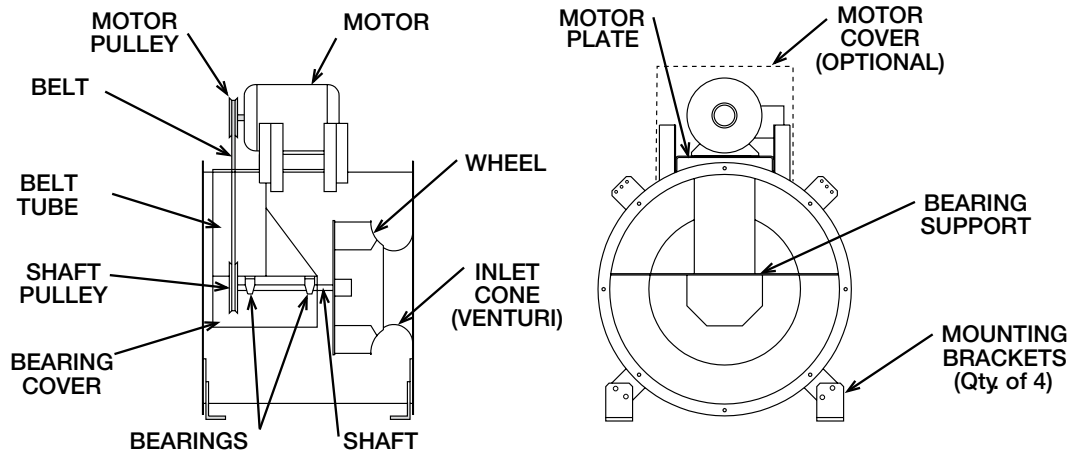

Troubleshooting

WARNING

Before taking any corrective action, make certain unit is not capable of operation during repairs.

AVERTISSEMENT

Avant d'entreprendre toute action corrective, s'assurer que l'appareil ne pourra pas fonctionner durant les réparations.

Problem	Cause	Corrective Action
Excessive Noise	Wheel Rubbing Inlet	Adjust wheel and/or inlet cone. Tighten wheel hub or bearing collars on shaft.
	V-Belt Drive	Tighten sheaves on motor/fan shaft. Adjust belt tension. Align sheaves properly (see procedure). Replace worn belts or sheaves.
	Bearings	Replace defective bearing(s). Lubricate bearings. Tighten collars and fasteners.
	Wheel Unbalance	Clean all dirt off wheel. Check wheel balance.
Low CFM	Fan	Check wheel for correct rotation.
	Duct System	Higher pressure than design. Filters need replacement.
High CFM	Fan	Decrease fan speed.
	Duct System	Resize ductwork. Access door, filters, dampers not installed.
Static Pressure Wrong	Duct system has more or less restriction than anticipated	Remove obstructions in system. Use correction factor to adjust for temperature/altitude. Resize ductwork. Clean filters/coils. Change fan speed.*
High Motor Amp Draw	Fan	Check rotation of wheel. Reduce fan speed.
	Duct System	Resize ductwork. Check proper operation of isolation and bypass dampers. Check filters and access doors.
Fan Doesn't Operate	Electrical Supply	Check fuses/circuit breakers. Check for switches turned off or disconnected. Check for correct supply voltage.
	Drive	Check for broken belts. Tighten loose pulleys.
	Motor	Assure motor is correct horsepower and not tripping overload protector.
Overheated Bearing	Lubrication	Check for excessive or insufficient grease in the bearing.
	Mechanical	Replace damaged bearing. Relieve excessive belt tension. Align bearings. Check for bent shaft.
Excessive Vibration	Belts	Adjust tightness of belts. Replacement belts should be a matched set.
	System Unbalance	Check alignment of shaft, motor and pulleys. Adjustable pitch pulleys with motors over 15 hp are especially prone to unbalance. Check wheel balance, rebalance if necessary.

* Always check motor amps and compare to nameplate rating. Excessive fan speed may overload the motor and result in motor failure. Do not exceed the maximum cataloged rpm of the fan.

Maintenance Log

Date _____ Time _____ AM/PM

Notes: _____

Date _____ Time _____ AM/PM

Notes: _____

Date _____ Time _____ AM/PM

Notes: _____

Date _____ Time _____ AM/PM

Notes: _____

Date _____ Time _____ AM/PM

Notes: _____

Date _____ Time _____ AM/PM

Notes: _____

Date _____ Time _____ AM/PM

Notes: _____

Date _____ Time _____ AM/PM

Notes: _____



Larkin Industries, Inc.
114 David Green Rd., Birmingham, AL 35244
Phone: 1.800.322.4036 Fax: 1.205.987.0583
Email: Sales@larkinhoods.com